



# GCSE

## Mathematics

---

**Session:** 1994 June  
**Type:** Question paper  
**Code:** 1660

Centre Number      Candidate Number

--	--

Candidate Name \_\_\_\_\_

**MIDLAND EXAMINING GROUP**

**1660/1**

**General Certificate of Secondary Education**

**MATHEMATICS (without Course Work)**

**PAPER 1 (Basic Tier)**

Tuesday

**7 JUNE 1994**

Afternoon

2 hours

Candidates answer on the question paper.

Additional materials:

Electronic calculator

Geometrical instruments

Tracing paper (optional)

**TIME** 2 hours

**INSTRUCTIONS TO CANDIDATES**

Write your name, Centre number and candidate number in the spaces at the top of this page.

Answer **all** questions.

Write your answers in the spaces provided on the question paper.

Show all your working. Marks may be given for working which shows that you know how to solve the problem, even if you get the answer wrong.

**INFORMATION FOR CANDIDATES**

The number of marks is given in brackets [ ] at the end of each question or part question.

You are expected to use an electronic calculator for this paper.

Unless otherwise instructed in the question, take  $\pi$  to be 3.142 or use the  $\pi$  button on your calculator.

FOR EXAMINER'S USE

--

**This question paper consists of 26 printed pages and 2 blank pages.**

## INFORMATION AND FORMULAE

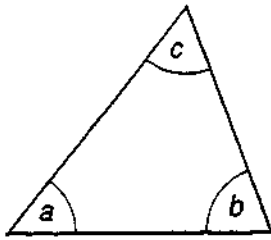

Angle sum of triangle  
 $a + b + c = 180^\circ$

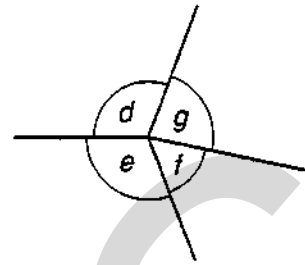

Angles at a point  
 $d + e + f + g = 360^\circ$

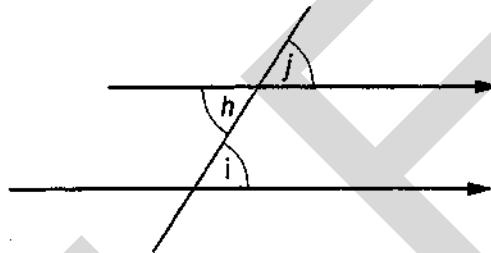

Parallel lines properties  
 $h = i$  and  $i = j$

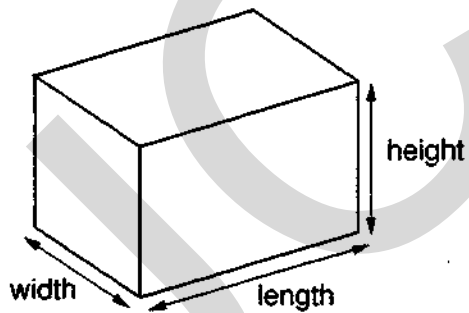

Volume of cuboid  
 $= \text{length} \times \text{width} \times \text{height}$

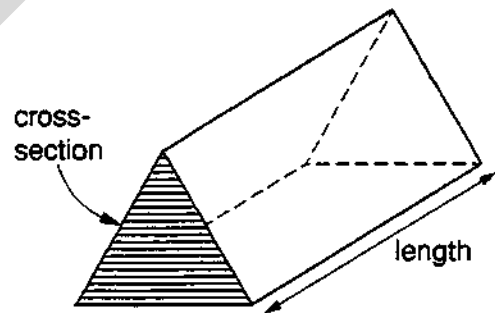

Volume of prism  
 $= \text{area of cross-section} \times \text{length}$

## SECTION A

Answer all questions in this section.

Show all your working.

- 1 (a) Write down in figures the number five thousand and seven.

Answer (a) \_\_\_\_\_ [1]

- (b) Subtract five hundred and ten from five thousand and seven.

.....

.....

Answer (b) \_\_\_\_\_ [2]

2

		COLUMN			
		1	2	4	8
ROW	1	1	2	4	8
	2	2	4	8	16
	3	3	6	12	24
	4	4	8	16	32

In the table above, write down the relationship between

- (a) the numbers in column 8 and the numbers in column 4,

Answer (a) \_\_\_\_\_ [2]

- (b) the numbers in row 3 and the numbers in row 2.

Answer (b) \_\_\_\_\_ [2]

3 A rectangle has sides of 8 cm and 5 cm.

(a) Calculate the perimeter of the rectangle.

.....  
.....

Answer (a) \_\_\_\_\_ cm [2]

(b) Construct the rectangle accurately in the space below.

\_\_\_\_\_ [2]

4

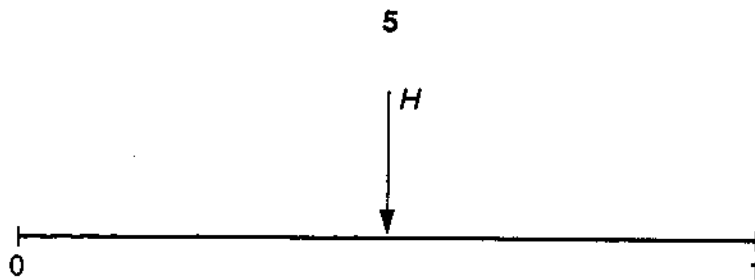

A probability line is shown above.

The arrow *H* on the line shows the probability that, when a coin is tossed, it will come down 'heads'.

(a)



Put an arrow *S* on the line to show the probability that it will snow where you live tomorrow.

Explain why you put your arrow in that position.

Explanation \_\_\_\_\_

\_\_\_\_\_ [2]

(b)



Put an arrow *L* on the line to show the probability that the next lorry you see travelling on the road will have a male driver.

Explain why you put your arrow in that position.

Explanation \_\_\_\_\_

\_\_\_\_\_ [2]

- 5 A school has to select one pupil to take part in a General Knowledge Quiz.

Kim and Pat took part in six trial quizzes.

The following lists show their scores:

Kim	28	24	21	27	24	26
Pat	33	19	16	32	34	16

Kim had a mean score of 25 with a range of 7.

- (a) Calculate Pat's mean score and range.

.....

.....

.....

Answer (a) Mean score = \_\_\_\_\_

Range = \_\_\_\_\_

[4]

- (b) Which pupil would you choose to represent the school? Explain the reason for your choice, referring to the mean scores and ranges.

Answer (b) Pupil \_\_\_\_\_

Reason \_\_\_\_\_

[2]

6

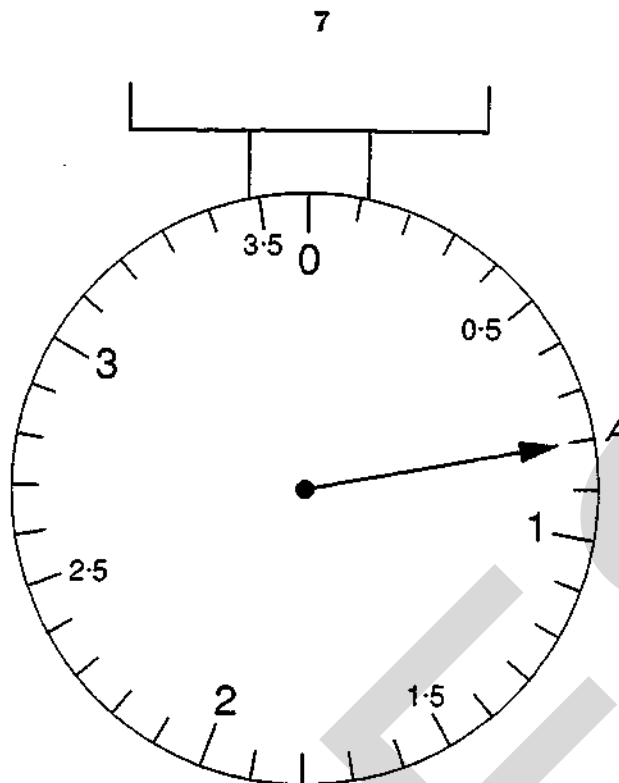

These kitchen scales weigh in kilograms.

(a) Write down the weight when the pointer is at A.

Answer (a) \_\_\_\_\_ kg [1]

(b) On the diagram draw another pointer B to indicate a weight of 2.85 kg. [2]

7 A cake weighs 850 grams.

20% of the cake is sugar.

Calculate the weight of sugar in the cake.

.....

.....

Answer \_\_\_\_\_ grams [4]



8

Image removed due to third party copyright restrictions



0  
A 822  
of 7 miles  
01

Reproduced from the 1980 Ordnance Survey  
1 : 50 000 Landranger map with the permission  
of the Controller of Her Majesty's Stationary  
Office © Crown Copyright

(a) On the map above, which farm has a grid reference of 045 412?

Answer (a) \_\_\_\_\_ [2]

(b) Write down the grid reference of Freehay, marked X on the map.

Answer (b) \_\_\_\_\_ [2]

(c) On the map, what is 6 cm due East of Freehay?

Answer (c) \_\_\_\_\_ [2]

9 Kish buys seven 19p stamps and eight 24p stamps. How much change should she receive from £10?

.....  
.....

Answer £ \_\_\_\_\_ [4]

10

9

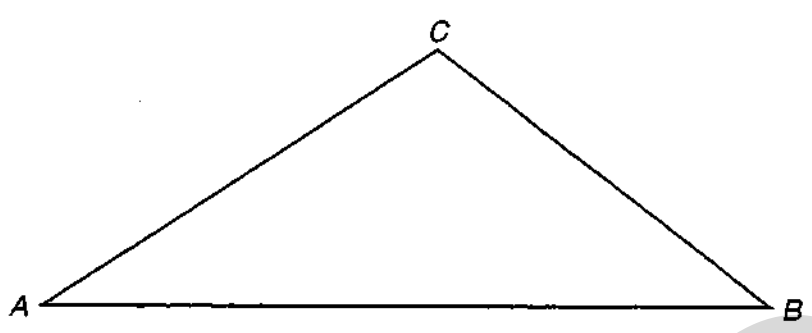

By making and using appropriate measurements, calculate the area of triangle *ABC* in square centimetres. State the measurements that you have made and show your working clearly.

.....

.....

.....

Answer \_\_\_\_\_ cm<sup>2</sup> [4]

11

### COUNCIL TAX ON HOUSES

The size of a Council Tax bill depends on the band in which the house is put.

There are eight bands, *A* to *H*.

Megtown Council sets the tax for houses in band *D* as £450.

For every £9 of tax in band *D*, householders pay

- |   |    |   |      |
|---|----|---|------|
| A | £6 | E | £11  |
| B | £7 | F | £13  |
| C | £8 | G | £15  |
| D | £9 | H | £18. |

Calculate the Megtown Council Tax for a house in

(a) band *H*,

.....

.....

Answer (a) £ \_\_\_\_\_ [2]

(b) band *A*.

.....

.....

Answer (b) £ \_\_\_\_\_ [2]

12 I thought of a number, doubled it and then took away 3.

The result was 21.

What is the number that I thought of?

.....  
.....

Answer \_\_\_\_\_ [2]

13            20    21    22    23    24    25    26    27    28    29

(a) In the row of numbers above,

- (i) circle all numbers divisible by 2 (e.g. 20),
- (ii) cross out all numbers divisible by 3 (e.g. 21),
- (iii) underline all numbers divisible by 5 (e.g. 25).

[3]

(b) Describe the numbers which are not circled, crossed out or underlined.

Answer. They are \_\_\_\_\_ numbers. [1]

14 The bar chart below shows the shoe sizes of a group of 16 year old boys.

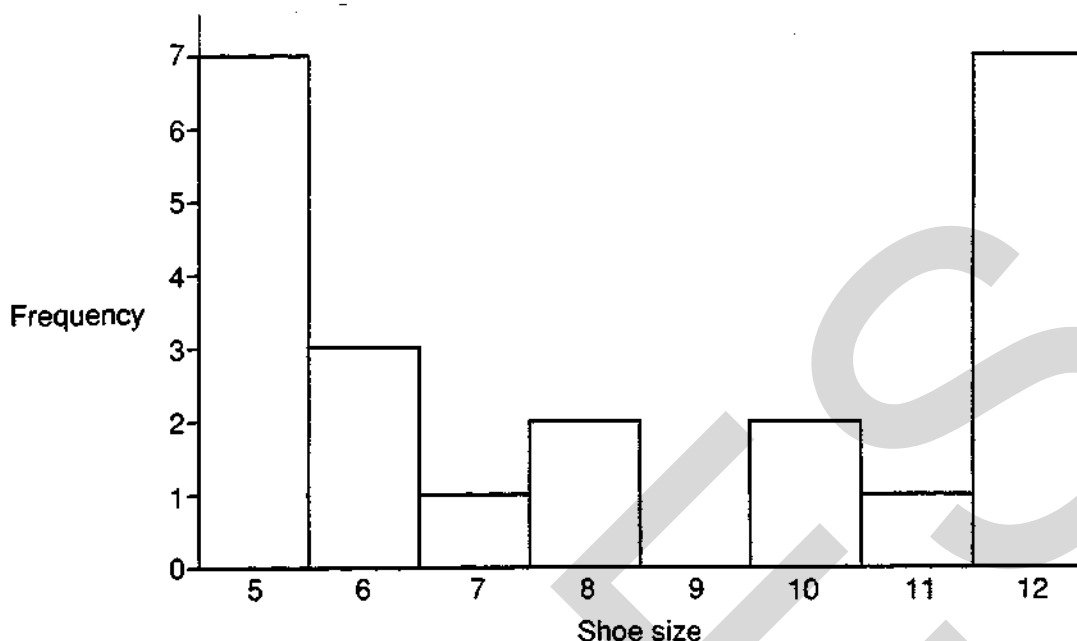

(a) How many boys are there in the group?

Answer (a) \_\_\_\_\_ [2]

(b) Comment on the shape of the bar chart, saying whether or not this is the shape you would expect.

Answer (b) \_\_\_\_\_  
 \_\_\_\_\_  
 \_\_\_\_\_ [2]

15 To build an extension to a house, Brickie Builders charge a price of £350 per square metre of floor space plus £1000.

Calculate the cost of an extension of 40 square metres of floor space.

.....  
 .....  
 .....

Answer £ \_\_\_\_\_ [4]

16 Consider the sequence

1, 5, 9, 13, 17, 21, 25, .....

(a) Find the next term in the sequence and explain how you obtained your answer.

*Answer*      Next term = \_\_\_\_\_

*Explanation* \_\_\_\_\_

[2]

(b) The  $n$ th term in the sequence is  $4n - 3$ .

Solve the equation  $4n - 3 = 397$  and explain what the answer tells you.

*Answer*       $n =$  \_\_\_\_\_

*Explanation* \_\_\_\_\_

[2]

17

WEATHER DATA for 1 October 1993					
	Sunshine (hrs)	Rainfall (mm)		Sunshine (hrs)	Rainfall (mm)
London	1.7	52	Newcastle	2.5	26
Birmingham	1.9	56	Norwich	2.7	18
Leeds	1.4	71	Plymouth	0.8	84
Nottingham	2.3	30	Glasgow	2.8	10

(a) On the grid below, data from the first 6 cities has been plotted. Plot the figures for Plymouth and Glasgow to complete the scatter diagram.

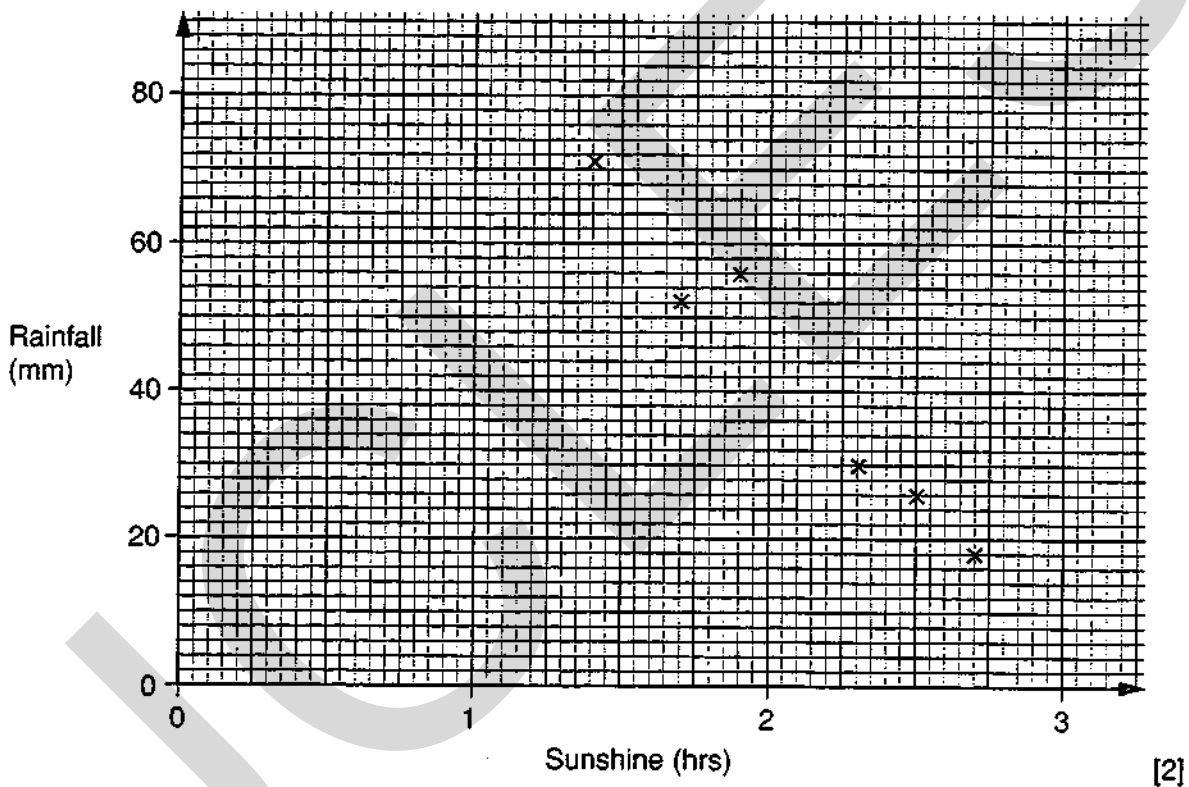

(b) What does the scatter diagram tell you about the relationship between sunshine and rainfall for 1 October 1993?

Answer \_\_\_\_\_

\_\_\_\_\_ [2]

18

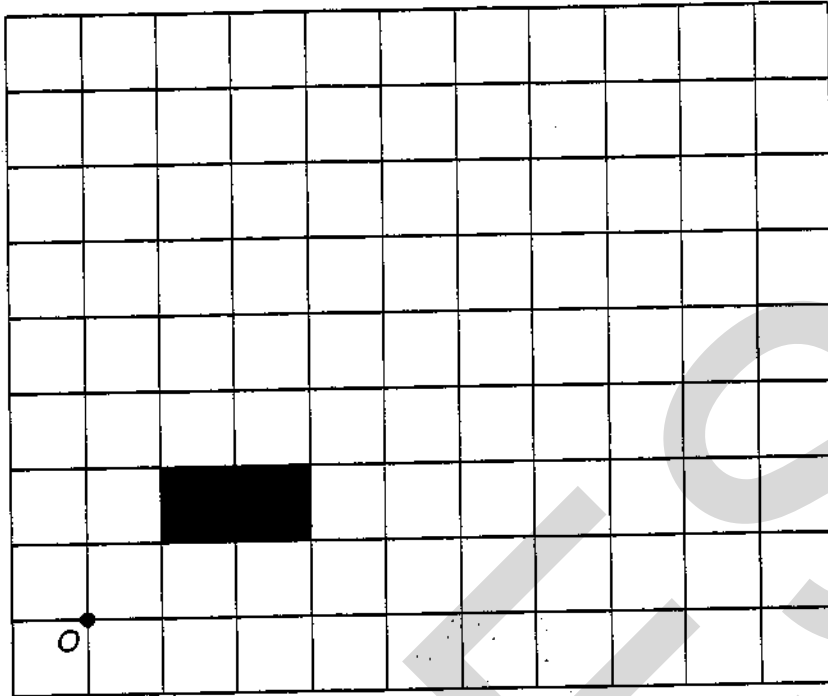

Using the point  $O$  as the centre of enlargement, enlarge the shaded rectangle with scale factor 3. [4]

19 (a)

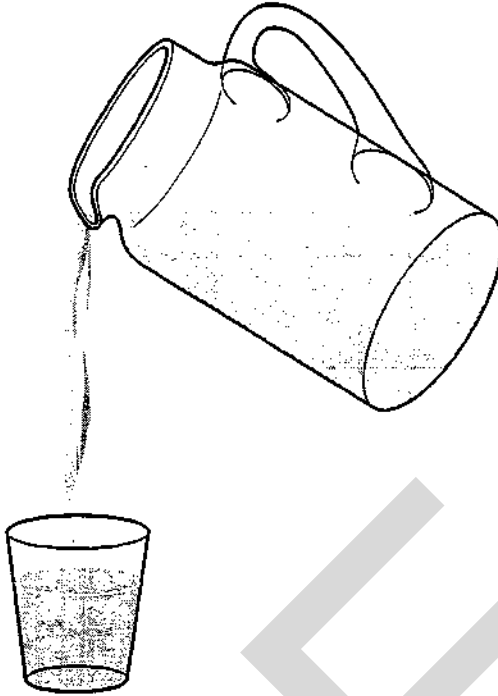

An orange drink is made by mixing water with concentrated orange juice.

$\frac{3}{4}$  of the orange drink is water.

How many litres of water will be in 12 litres of orange drink?

.....  
.....  
.....

Answer (a) \_\_\_\_\_ litres [3]

(b) It takes 100 g of flour to make 15 shortbread biscuits.

(i) Calculate the weight of flour needed to make 24 shortbread biscuits.

.....  
.....  
.....

Answer (b) (i) \_\_\_\_\_ g [3]

(ii) How many shortbread biscuits can be made from 1 kg of flour?

.....  
.....

Answer (b) (ii) \_\_\_\_\_ [1]



- 20 In Carberry, the temperature at midday was  $5^{\circ}\text{C}$ .  
At midnight the temperature had fallen by  $8^{\circ}\text{C}$ .  
What was the temperature at midnight?

.....  
.....

Answer \_\_\_\_\_ [2]

21

NOT TO SCALE

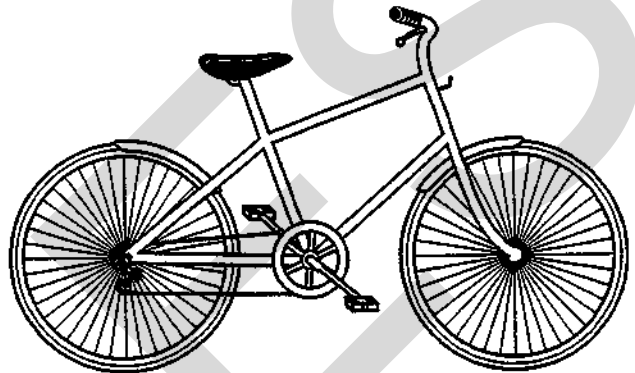
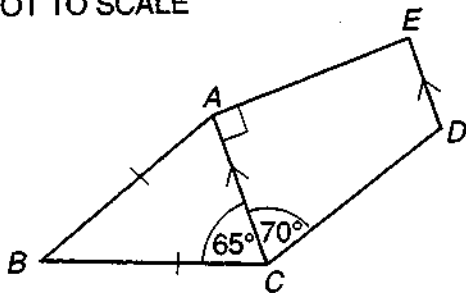

The pentagon  $ABCDE$  is the frame for Ibrahim's mountain bike.  
 $ABC$  is an isosceles triangle in which  $AB = BC$  and angle  $BCA = 65^{\circ}$ .  
In the quadrilateral  $ACDE$ , angle  $ACD = 70^{\circ}$ , angle  $CAE = 90^{\circ}$  and  $AC$  is parallel to  $ED$ .

- (a) Calculate angle  $ABC$ , giving a reason for each step of your working.

Answer (a) \_\_\_\_\_  
\_\_\_\_\_  
\_\_\_\_\_  
\_\_\_\_\_

angle  $ABC =$  \_\_\_\_\_ [4]

- (b) Calculate angle  $CDE$ , giving a reason for your answer.

Answer (b) \_\_\_\_\_  
\_\_\_\_\_  
\_\_\_\_\_

angle  $CDE =$  \_\_\_\_\_ [2]

- (c) The radius of each wheel is 34 cm.

Calculate the circumference of a wheel.

.....

.....

.....

Answer (c) \_\_\_\_\_ cm [2]

- 22 (a) Complete the statement in the answer space by putting numbers in the boxes.

.....

Answer (a)

$$\frac{2}{3} = \frac{\square}{15} = \frac{16}{\square} \quad [2]$$

- (b) Change  $\frac{7}{20}$  to a percentage.

.....

.....

Answer (b) \_\_\_\_\_ % [1]

23

### HOUSEHOLDS IN NEWTOWN WITH TELEVISION LICENCES

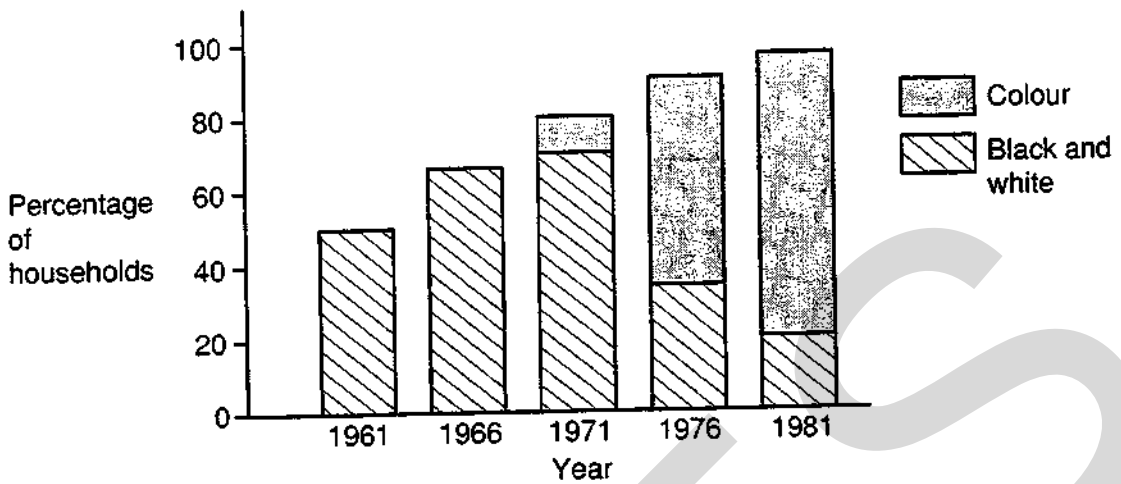

You have been asked to write an article about television viewing in Newtown since 1961. You have obtained the diagram above.

(a) What percentage of households had a television licence in 1966?

.....  
.....

Answer (a) \_\_\_\_\_ % [2]

(b) What percentage of households had a licence for colour television in 1976?

.....  
.....

Answer (b) \_\_\_\_\_ % [2]

(c) Comment on how the percentage of licences for colour television compared with the percentage of licences for black and white television over the years 1961–1981.

.....  
.....

Answer (c) \_\_\_\_\_

\_\_\_\_\_

\_\_\_\_\_ [2]

- (d) This year, 97% of the households have a television licence. If one household is chosen at random, what is the probability that they do **not** have a television licence?

.....  
 .....

Answer (d) \_\_\_\_\_ [2]

24

Row 1		1		Sum = 1
Row 2	3		5	Sum = 8 = 2 <sup>3</sup>
Row 3	7	9	11	Sum = 27 = 3 <sup>3</sup>

- (a) Write down the numbers and the Sum which continue the pattern in Row 4.

.....  
 .....

Answer (a) \_\_\_\_\_ [2]

- (b) Which Row will have a Sum = 1000?

.....  
 .....

Answer (b) \_\_\_\_\_ [1]

- (c) What is the Sum of Row 20?

.....  
 .....

Answer (c) \_\_\_\_\_ [2]

- (d) The first number in a row is  $x$ .

What is the second number in this row? Give your answer in terms of  $x$ .

.....  
 .....

Answer (d) \_\_\_\_\_ [1]

25 The diagram shows a map of part of the North Devon coast.

The bearing of a ship from Hartland Point is  $070^\circ$ .

Its bearing from Appledore is  $320^\circ$ .

Showing your construction lines, mark the position of the ship on the map. Label the position with the letter S.

*Answer*

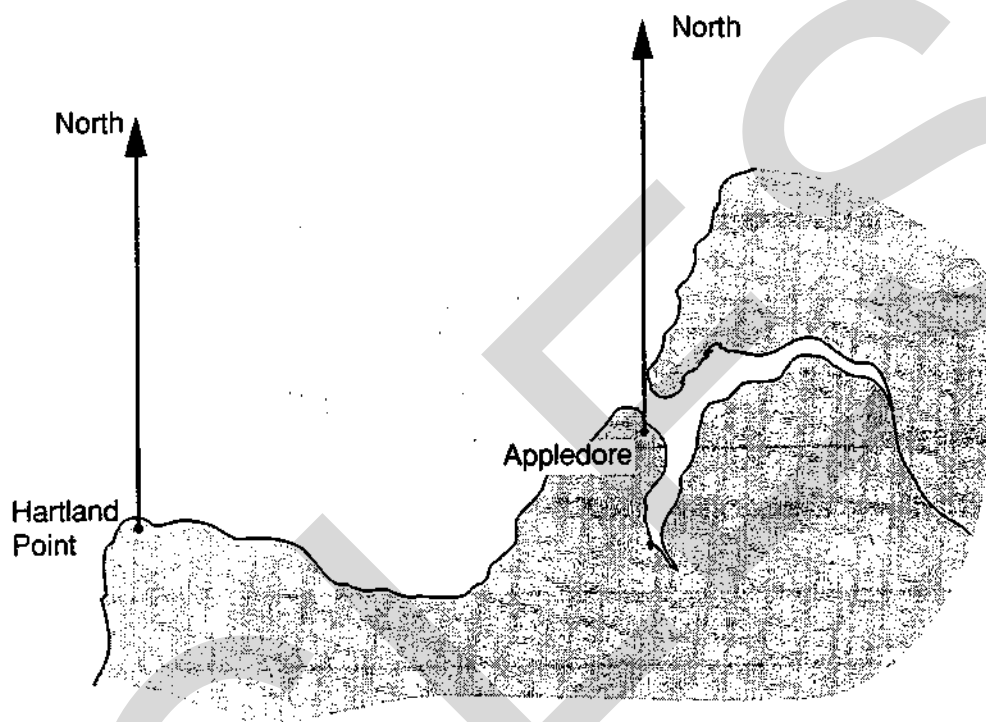

[4]

26

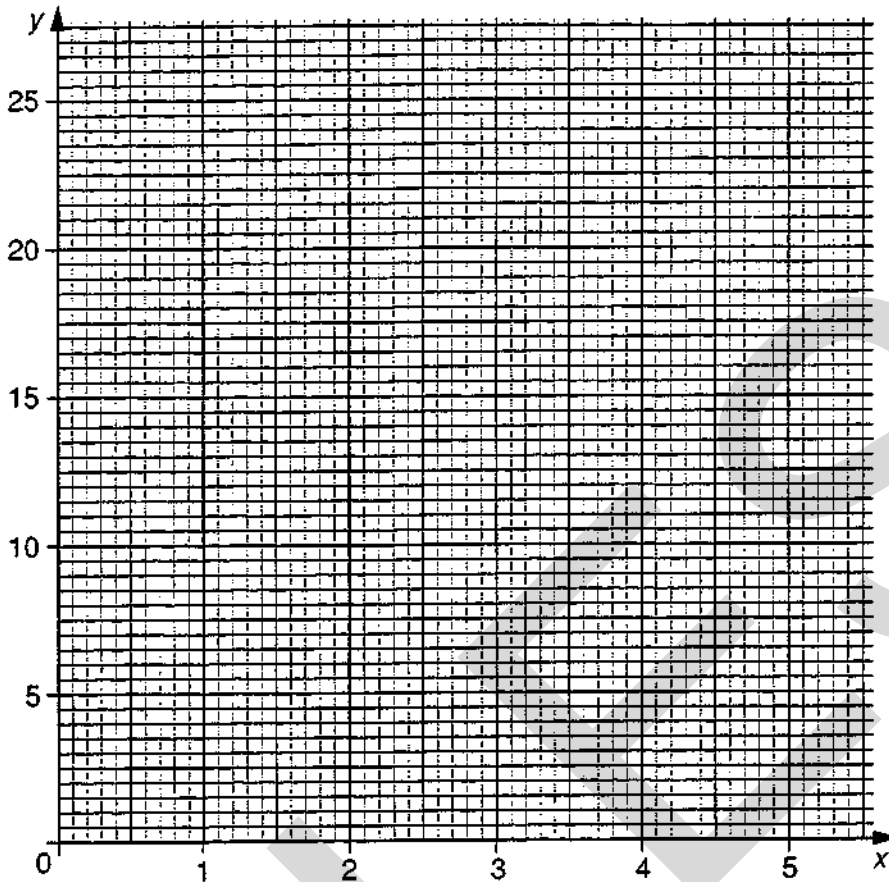

$x$	0	1	2	3	4	5
$y$	0	1	4	9	16	25

(a) Using the given table of values, draw the graph of  $y = x^2$  on the grid above. [2]

(b) Use your graph to find the approximate value of  $x$  when  $y = 14$ .

.....

Answer (b) \_\_\_\_\_ [1]

(c) Use trial and improvement to find a value of  $x$  for which  $14 = x^2$ .  
Show every step of your working and give your answer correct to 2 decimal places.

Answer (c) \_\_\_\_\_

\_\_\_\_\_

\_\_\_\_\_

\_\_\_\_\_

\_\_\_\_\_ [3]

- 27 (a) A bag contains 2 red marbles, 1 blue marble and 1 yellow marble.  
A second bag contains 1 red marble, 2 blue marbles and 1 yellow marble.  
A marble is drawn from each bag.  
Complete the table showing all the possible pairs of colours.

Answer (a)

Marble from  
second bag

	R	B	B	Y	
Marble from first bag	R	RR	RB	RB	RY
	R	RR			
	B	BR			
	Y	YR			

[2]

- (b) 2 marbles are drawn from a third bag.

The probability that they are both of the same colour is  $\frac{5}{9}$ .  
What is the probability that they are of different colours?

.....

.....

Answer (b) \_\_\_\_\_ [2]

**SECTION B**

*Answer all questions in this section.*

*Show all your working.*

28

**CHARITIES**

**Income from voluntary donations in one year**

<i>Charity</i>	<i>Income £ (millions)</i>
Help the Aged	30
R.S.P.C.A.	25
National Trust	50
Oxfam	35
Save the Children Fund	40

Re-present the information in an appropriate diagram.

[10]



- 29 The diagram below shows part of Durer's magic square. When the magic square is complete, each of the numbers 1, 2, 3, ..... , 16 is placed in one of the sixteen small squares. Nine small squares have been filled in already.

The four numbers in each row of the complete magic square add up to 34.

The four numbers in each column add up to 34.

16			13
5	10		8
	6		
4	15		1

- (a) Use the information to complete the magic square above. [5]

- (b) Copy your completed magic square four times in the magic squares below.

16			13
5	10		8
	6		
4	15		1

16			13
5	10		8
	6		
4	15		1

16			13
5	10		8
	6		
4	15		1

16			13
5	10		8
	6		
4	15		1

There are at least four groups of four numbers, other than rows and columns, which add up to 34.

Shade a different one of these other groups of four numbers in each of the squares. [5]

30 (a)

## USES OF WATER

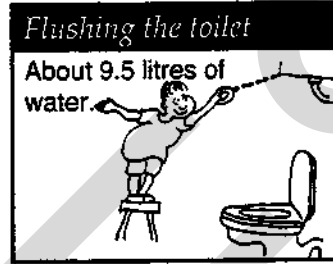
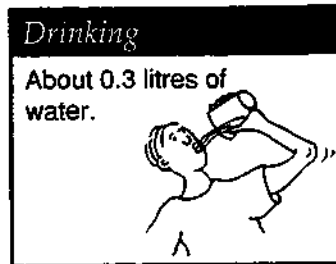
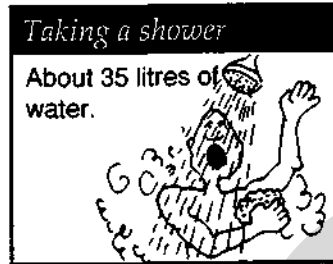
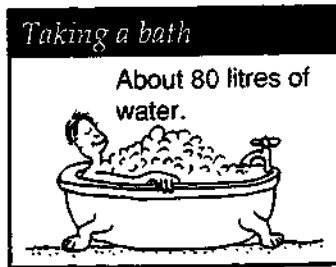

The information shown above does not give all the uses of water.  
Give another example, with an approximate amount of water.

*Answer* Example \_\_\_\_\_

Approximate amount \_\_\_\_\_ litres [4]

**QUESTION 30 CONTINUES ON THE NEXT PAGE**

(b) The following is an extract from the Isle of Pitt News.

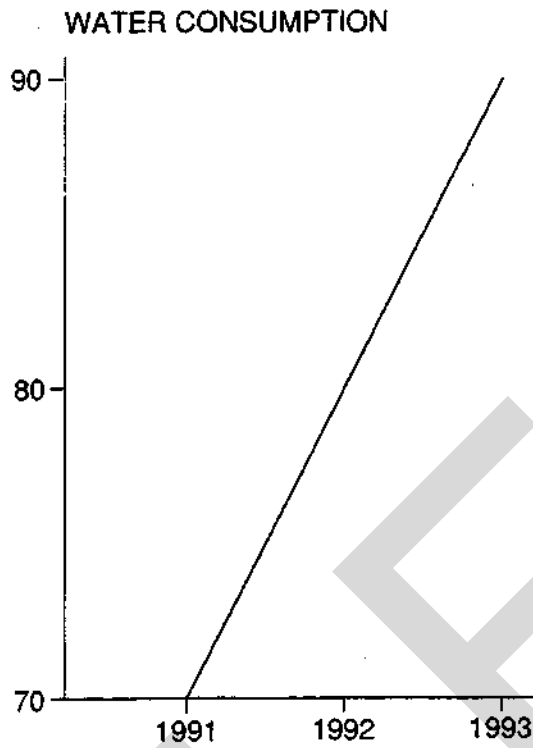

'The total water consumption on the Isle of Pitt showed a staggering increase between 1991 and 1993.'

Comment on the presentation of information above.

.....

.....

.....

.....

.....

.....

.....

[6]

Centre Number Candidate Number

Candidate Name \_\_\_\_\_

--	--

**MIDLAND EXAMINING GROUP**

**1660/2**

General Certificate of Secondary Education

**MATHEMATICS (without Course Work)**

PAPER 2 (Central Tier)

Tuesday

**7 JUNE 1994**

Afternoon

2 hours 30 minutes

Additional materials:

Answer paper

Electronic calculator

Geometrical instruments

Tracing paper (optional)

**TIME** 2 hours 30 minutes

**INSTRUCTIONS TO CANDIDATES**

Write your name, Centre number and candidate number in the spaces at the top of this page and on all separate answer paper used.

Show all your working. Marks may be given for working which shows that you know how to solve the problem, even if you get the answer wrong.

**Section A**

Answer all questions.

Write your answers in the spaces provided on the question paper.

**Section B**

Answer all questions.

Write your answers on the writing paper provided.

At the end of the examination, fasten the separate answer paper securely to the question paper, with the question paper on top of the answer paper.

**INFORMATION FOR CANDIDATES**

The number of marks is given in brackets [ ] at the end of each question or part question.

You are expected to use an electronic calculator for this paper.

Unless otherwise instructed in the question, take  $\pi$  to be 3.142 or use the  $\pi$  button on your calculator.

FOR EXAMINER'S USE

--

This question paper consists of 24 printed pages.

# INFORMATION AND FORMULAE

## MENSURATION

Parallelogram

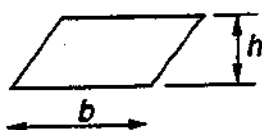

$$\text{Area} = bh$$

Trapezium

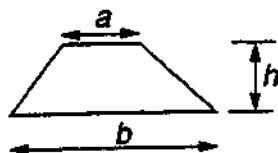

$$\text{Area} = \frac{1}{2}(a + b)h$$

Cuboid

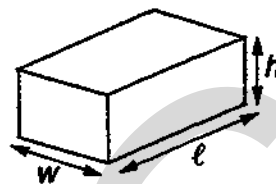

$$\text{Volume} = lwh$$

Prism  
eg triangular prism

Volume = area of cross-section  $\times$  length



eg cylinder



## TRIGONOMETRY

Right-angled triangle

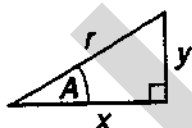

$$r^2 = x^2 + y^2, \text{ (result of Pythagoras)}$$

$$x = r \cos A, \quad y = r \sin A, \quad y = x \tan A$$

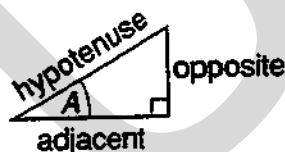

$$\sin A = \frac{\text{opposite}}{\text{hypotenuse}}, \quad \cos A = \frac{\text{adjacent}}{\text{hypotenuse}}, \quad \tan A = \frac{\text{opposite}}{\text{adjacent}}$$

## NUMBER

Standard form is  $a \times 10^n$  where  $1 \leq a < 10$  and  $n$  is an integer.

## SECTION A

Answer all questions in this section.

Write your answers in the spaces provided on the question paper.

Show all your working.

1 (a)



An orange drink is made by mixing water with concentrated orange juice.

$\frac{3}{4}$  of the orange drink is water.

How many litres of water will be in 12 litres of orange drink?

.....

.....

.....

Answer (a) \_\_\_\_\_ litres [3]

(b) It takes 100 g of flour to make 15 shortbread biscuits.

(i) Calculate the weight of flour needed to make 24 shortbread biscuits.

.....

.....

.....

Answer (b) (i) \_\_\_\_\_ g [3]

(ii) How many shortbread biscuits can be made from 1 kg of flour?

.....

.....

Answer (b) (ii) \_\_\_\_\_ [1]

- 2 In Carberry, the temperature at midday was  $5^{\circ}\text{C}$ .  
At midnight the temperature had fallen by  $8^{\circ}\text{C}$ .  
What was the temperature at midnight?

.....  
.....

Answer \_\_\_\_\_ [2]

3

NOT TO SCALE

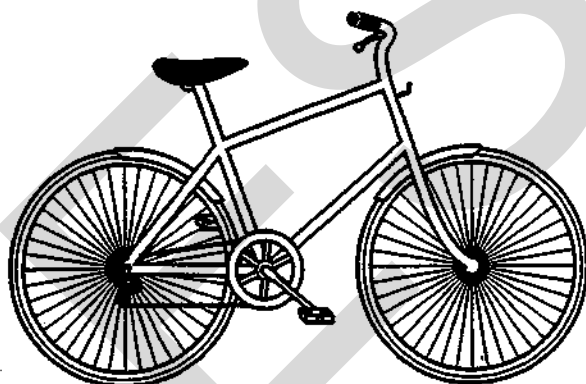
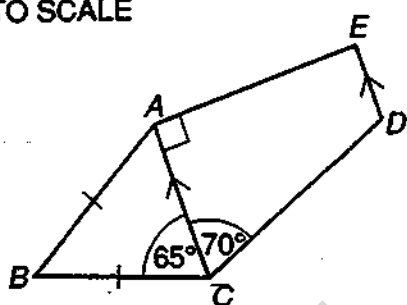

- The pentagon  $ABCDE$  is the frame for Ibrahim's mountain bike.  
 $ABC$  is an isosceles triangle in which  $AB = BC$  and angle  $BCA = 65^{\circ}$ .  
In the quadrilateral  $ACDE$ , angle  $ACD = 70^{\circ}$ , angle  $CAE = 90^{\circ}$  and  $AC$  is parallel to  $ED$ .  
(a) Calculate angle  $ABC$ , giving a reason for each step of your working.

Answer (a) \_\_\_\_\_  
\_\_\_\_\_  
\_\_\_\_\_  
\_\_\_\_\_

angle  $ABC =$  \_\_\_\_\_ [4]

- (b) Calculate angle  $CDE$ , giving a reason for your answer.

Answer (b) \_\_\_\_\_  
\_\_\_\_\_  
\_\_\_\_\_

angle  $CDE =$  \_\_\_\_\_ [2]

- (c) The radius of each wheel is 34 cm.  
Calculate the circumference of a wheel.

.....

.....

.....

Answer (c) \_\_\_\_\_ cm [2]

- 4 (a) Complete the statement in the answer space by putting numbers in the boxes.

.....

Answer (a)  $\frac{2}{3} = \frac{\boxed{\phantom{00}}}{15} = \frac{16}{\boxed{\phantom{00}}}$  [2]

- (b) Change  $\frac{7}{20}$  to a percentage.

.....

.....

Answer (b) \_\_\_\_\_ % [1]



5

## HOUSEHOLDS IN NEWTOWN WITH TELEVISION LICENCES

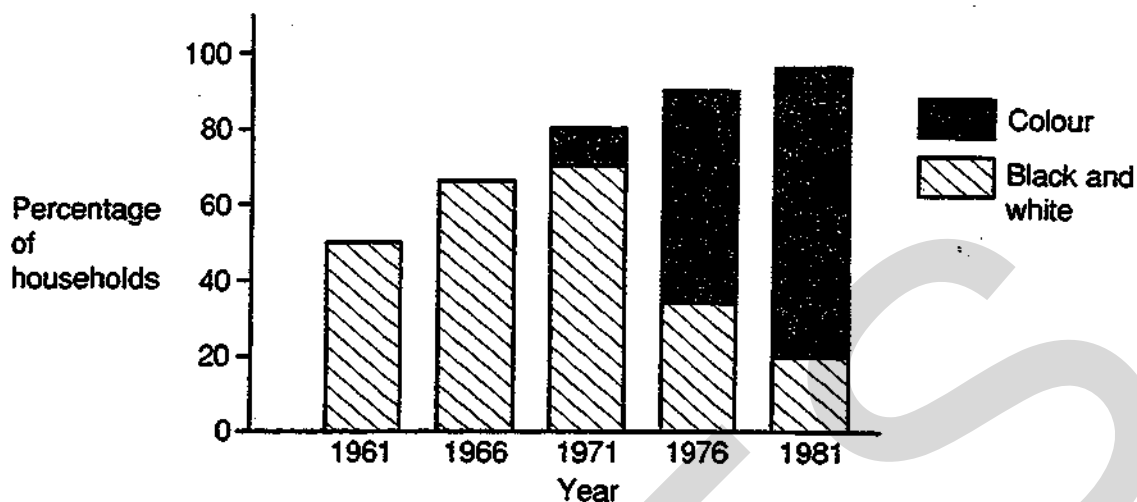

You have been asked to write an article about television viewing in Newtown since 1961. You have obtained the diagram above.

- (a) What percentage of households had a television licence in 1966?

.....

.....

Answer (a) \_\_\_\_\_ % [2]

- (b) What percentage of households had a licence for colour television in 1976?

.....

.....

Answer (b) \_\_\_\_\_ % [2]

- (c) Comment on how the percentage of licences for colour television compared with the percentage of licences for black and white television over the years 1961–1981.

.....

.....

Answer (c) \_\_\_\_\_

\_\_\_\_\_

\_\_\_\_\_

[2]

(d) This year, 97% of the households have a television licence.

If one household is chosen at random, what is the probability that they do not have a television licence?

.....  
 .....

Answer (d) \_\_\_\_\_ [2]

6

Row 1			1		Sum =	1
Row 2		3		5	Sum =	$8 = 2^3$
Row 3	7		9		Sum =	$27 = 3^3$

(a) Write down the numbers and the Sum which continue the pattern in Row 4.

.....  
 .....

Answer (a) \_\_\_\_\_ [2]

(b) Which Row will have a Sum = 1000?

.....  
 .....

Answer (b) \_\_\_\_\_ [1]

(c) What is the Sum of Row 20?

.....  
 .....

Answer (c) \_\_\_\_\_ [2]

(d) The first number in a row is  $x$ .

What is the second number in this row? Give your answer in terms of  $x$ .

.....  
 .....

Answer (d) \_\_\_\_\_ [1]

7 The diagram shows a map of part of the North Devon coast.

The bearing of a ship from Hartland Point is  $070^\circ$ .

Its bearing from Appledore is  $320^\circ$ .

Showing your construction lines, mark the position of the ship on the map. Label the position with the letter *S*.

*Answer*

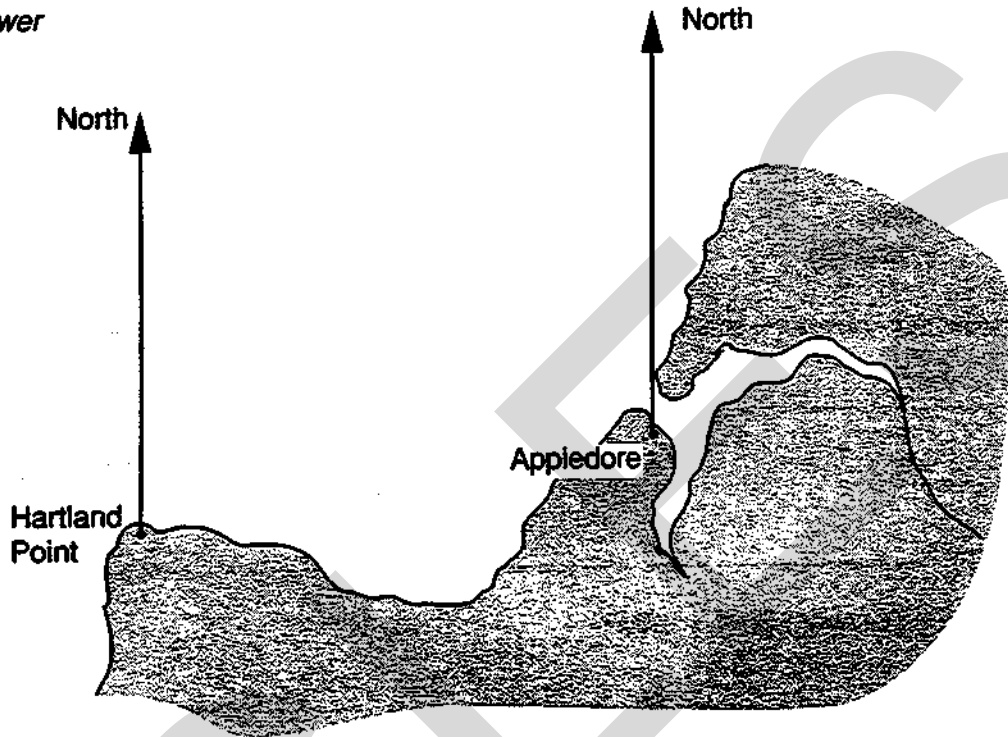

[4]

8

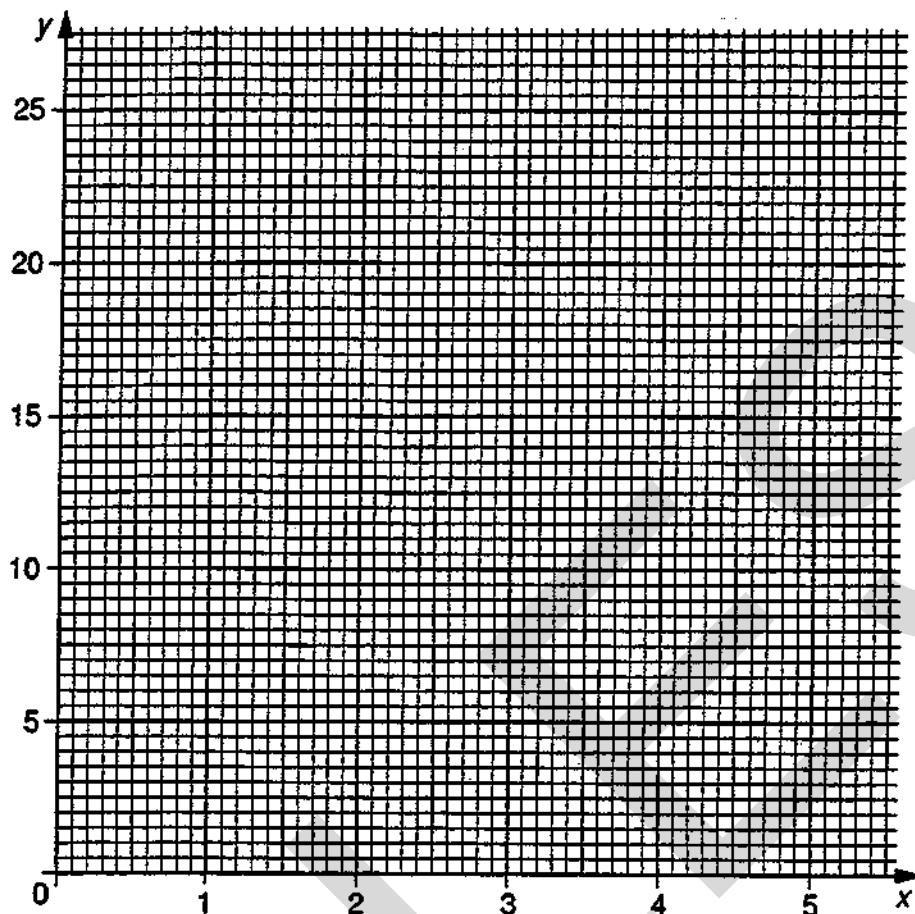

$x$	0	1	2	3	4	5
$y$	0	1	4	9	16	25

- (a) Using the given table of values, draw the graph of  $y = x^2$  on the grid above. [2]
- (b) Use your graph to find the approximate value of  $x$  when  $y = 14$ .

.....

Answer (b) \_\_\_\_\_ [1]

- (c) Use trial and improvement to find a value of  $x$  for which  $14 = x^2$ .  
Show every step of your working and give your answer correct to 2 decimal places.

Answer (c) \_\_\_\_\_

\_\_\_\_\_

\_\_\_\_\_

\_\_\_\_\_

\_\_\_\_\_ [3]

- 9 (a) A bag contains 2 red marbles, 1 blue marble and 1 yellow marble.  
A second bag contains 1 red marble, 2 blue marbles and 1 yellow marble.  
A marble is drawn from each bag.  
Complete the table showing all the possible pairs of colours.

Answer (a)

		Marble from second bag			
		R	B	B	Y
Marble from first bag	R	RR	RB	RB	RY
	R	RR			
	B	BR			
	Y	YR			

[2]

- (b) 2 marbles are drawn from a third bag.  
The probability that they are both of the same colour is  $\frac{5}{9}$ .  
What is the probability that they are of different colours?

.....

.....

Answer (b) \_\_\_\_\_ [2]

10

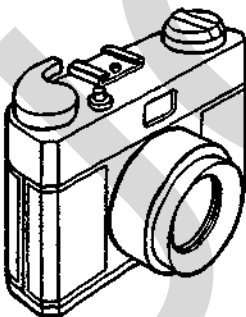

**BARGAIN BUY**  
**Only \$109.60**  
Autofocus Camera & Case

This camera was for sale at a shop in Singapore.  
The rate of exchange was £1 = \$2.73.  
Calculate the cost of the camera in British money, correct to the nearest penny.

.....

.....

.....

Answer \_\_\_\_\_ [3]

- 11 (a) Write down the next term in the series

$$x, x^3, x^5, x^7,$$

.....  
 .....

Answer (a) \_\_\_\_\_ [2]

- (b) What is the value of this term when  $x = 1$ ?

.....  
 .....

Answer (b) \_\_\_\_\_ [1]

- 12 The maximum speed,  $s$  km/h, at which a train can travel round a circular arc of railway track with a radius of  $r$  metres is given by

$$s = k\sqrt{r}.$$

When the radius is 100 m, the maximum speed is 35 km/h.

What is the maximum speed when the radius is 500 m?

.....  
 .....

Answer \_\_\_\_\_ [3]

- 13 Between 1950 and 1985 the number of people living in towns and cities in developing countries increased from  $2.86 \times 10^8$  to  $1.14 \times 10^9$ .

Calculate the increase in the number of people, giving your answer in standard form.

.....  
 .....

Answer \_\_\_\_\_ [3]

14

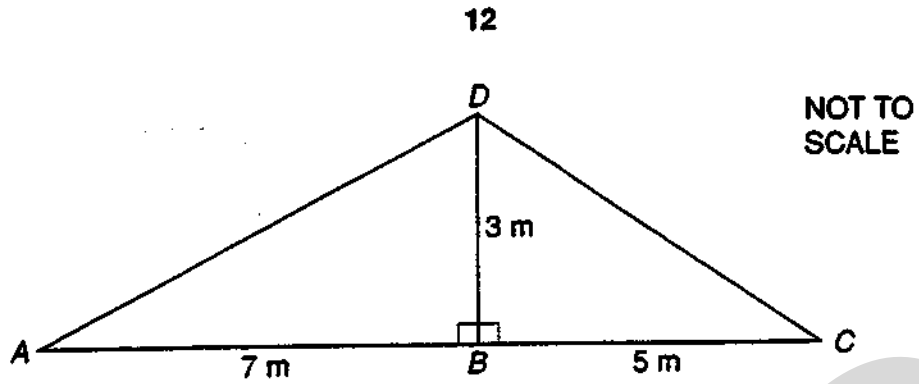

The diagram shows a roofing frame  $ABCD$ .

$AB = 7$  m,  $BC = 5$  m,  $DB = 3$  m, angle  $ABD =$  angle  $DBC = 90^\circ$ .

(a) Calculate the length of  $AD$ .

.....

.....

.....

.....

Answer (a) \_\_\_\_\_ m [3]

(b) Calculate the size of angle  $DCB$ .

.....

.....

.....

.....

Answer (b) \_\_\_\_\_ [3]

15 (a) List all the integers which satisfy

$$-2 < n \leq 3.$$

.....  
.....

Answer (a) \_\_\_\_\_ [3]

(b) Ajaz said 'I thought of an integer, multiplied it by 3 then subtracted 2.

The answer was between 47 and 62'.

List the integers that Ajaz could have used.

.....

Answer (b) \_\_\_\_\_ [3]



- 16 (a) A parcel is weighed on digital scales which record weight correct to the nearest one pound. The scales record 12 pounds. What is the least possible weight of the parcel?

Answer (a) \_\_\_\_\_ pounds [1]

- (b) (i) Convert 12.35 pounds to kilograms, taking 1 kg to be 2.2 pounds.

Write down all the figures shown on your calculator display.

.....  
.....  
.....

Answer (b) (i) \_\_\_\_\_ kg

- (ii) Write down your answer to part (b) (i) correct to the nearest kilogram.

Answer (b) (ii) \_\_\_\_\_ kg  
[3]

- (c) A second parcel is weighed on the digital scales and its weight is also recorded as 12 pounds.

When the scales are set to record weights in kilograms, correct to the nearest kilogram, the weights shown for the parcels are not the same.

Suggest a possible reason for this.

.....  
.....  
.....

Answer (c) \_\_\_\_\_

\_\_\_\_\_  
\_\_\_\_\_  
\_\_\_\_\_

[2]

17 The table below gives information about the expected lifetimes, in hours, of 200 light bulbs.

Lifetime ( $t$ )	$0 < t \leq 400$	$400 < t \leq 800$	$800 < t \leq 1200$	$1200 < t \leq 1600$	$1600 < t \leq 2000$
Frequency	32	56	90	16	6

(a) Mr Jones buys one of the light bulbs.

(i) What is the probability that it will not last more than 400 hours?

.....

.....

Answer (a) (i) \_\_\_\_\_ [3]

(ii) What is the probability that it will last at least 800 hours but not more than 1600 hours?

.....

.....

Answer (a) (ii) \_\_\_\_\_ [3]

(b) Using the given axes, draw a frequency polygon to illustrate the information in the table.

Answer

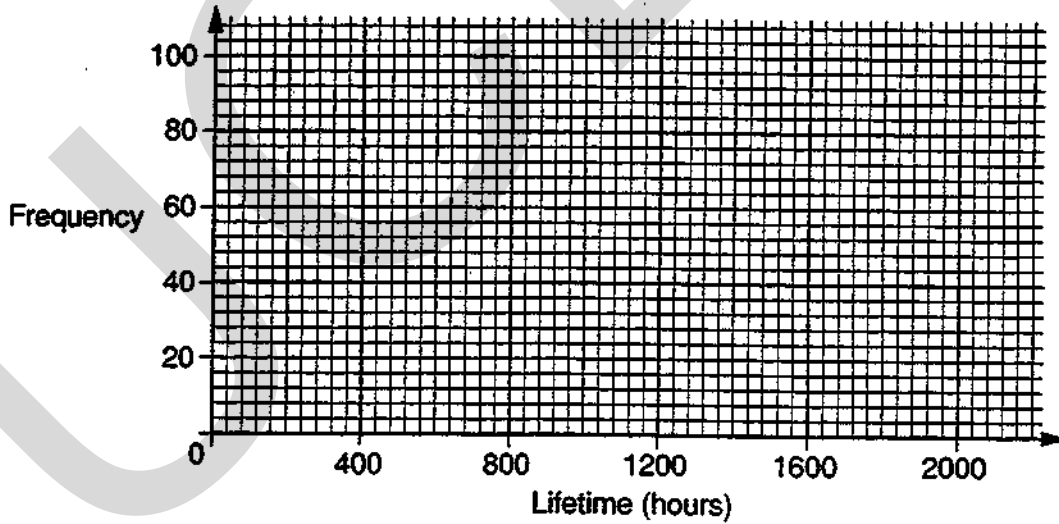

[3]

- 18 (a) Factorise completely  $12p^2q - 15pq^2$ .

.....  
.....  
.....

Answer (a) \_\_\_\_\_ [2]

- (b) Expand and simplify  $(2x - 3)(x + 5)$ .

.....  
.....  
.....

Answer (b) \_\_\_\_\_ [2]

- (c) The cost,  $C$  pence, of printing  $n$  party invitations is given by

$$C = 120 + 40n.$$

Find a formula for  $n$  in terms of  $C$ .

.....  
.....  
.....

Answer (c) \_\_\_\_\_ [2]

19

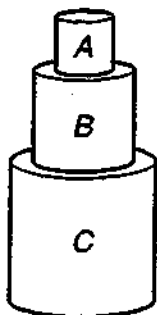
Not  
to  
Scale

A child builds a tower from three similar cylindrical blocks.

The smallest block, A, has radius 2.5 cm and height 6 cm.

- (a) Find the volume of the smallest block.

.....

.....

.....

Answer (a) \_\_\_\_\_ cm<sup>3</sup> [3]

- (b) Block B is an enlargement of A and block C is an enlargement of B, each with a scale factor of  $1\frac{3}{4}$ .

Find the total height of the tower.

.....

.....

.....

Answer (b) \_\_\_\_\_ cm [3]

18

20

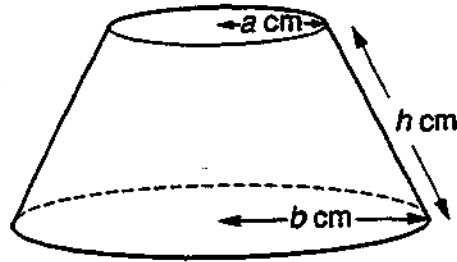

One of the formulae in the list below can be used to calculate the area of material needed to make the curved surface of the lampshade in the diagram.

- (i)  $\pi h(a + b)^2$ ,
- (ii)  $\pi h^2(a + b)$ ,
- (iii)  $\pi h(a + b)$ ,
- (iv)  $\pi h^2(a + b)^2$ .

State which formula is correct. Give a reason for your answer.

.....

.....

Answer Formula is \_\_\_\_\_

because \_\_\_\_\_

\_\_\_\_\_

\_\_\_\_\_ [3]

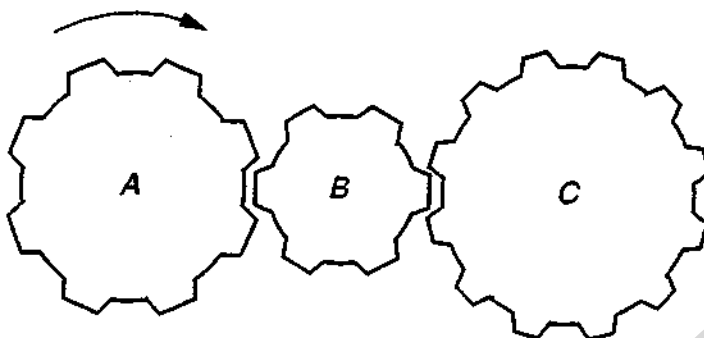

The diagram shows three interlocking cog wheels.

Wheel A has 8 cogs.

Wheel B has 6 cogs.

Wheel C has 12 cogs.

(a) Wheel A turns clockwise. In which direction does wheel B turn?

Answer (a) \_\_\_\_\_ [1]

(b) Wheel A makes 3 complete revolutions.

(i) How many complete revolutions does wheel B make?

.....  
.....

Answer (b) (i) \_\_\_\_\_ [1]

(ii) How many complete revolutions does wheel C make?

.....  
.....

Answer (b) (ii) \_\_\_\_\_ [1]

22 Alan, Barbara and Chris usually travel on the same bus to school.

- (a) Complete the following table by listing all the possible outcomes of Alan (A), Barbara (B) and Chris (C) trying to catch the bus. Use a tick to indicate 'catches the bus' and a cross to indicate 'does not catch the bus'.

Answer (a)

A✓	B✓	C✓
A✓	B✓	C✗

[2]

- (b) On any one day, the probability that Alan catches the bus is 0.8,  
the probability that Barbara catches the bus is 0.9 and  
the probability that Chris catches the bus is 0.75 .

- (i) Calculate the probability that only Alan and Barbara catch the bus on any one day.

.....  
 .....

Answer (b) (i) \_\_\_\_\_ [3]

- (ii) Calculate the probability that at least two of the three pupils catch the bus on any one day.

.....  
 .....

Answer (b) (ii) \_\_\_\_\_ [4]

23 The formula to convert temperatures from degrees Fahrenheit (°F) into degrees Celsius (°C) is

$$C = \frac{5}{9} (F - 32).$$

Calculate the temperature in degrees Celsius which is equivalent to a temperature of  $-7^{\circ}F$ .

.....  
 .....

Answer \_\_\_\_\_ °C [2]

21

24

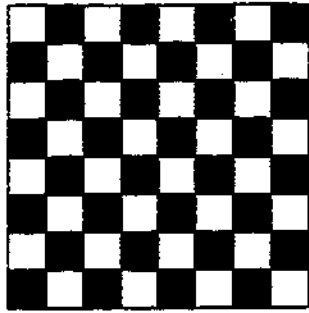

Centuries ago, a man promised to give his wife some grains of rice. He took a chess board and placed one grain on the first square, two grains on the second square, four grains on the third square, eight grains on the fourth square, and so on.

If he had completed all 64 squares on the chessboard he would have used approximately  $1.845 \times 10^{19}$  grains of rice.

One grain of rice weighs about 0.01 grams.

Calculate an estimate of the weight of rice used.

Give your answer in tonnes, correct to one significant figure.

[1 tonne = 1000 kg.]

.....

.....

.....

Answer \_\_\_\_\_ tonnes [4]



## SECTION B

*Answer all questions in this section.*

*Write all your answers on the writing paper provided.*

*Show all your working.*

- 25 The diagram below shows part of Dürer's magic square.

When the magic square is complete, each of the numbers 1, 2, 3, ....., 16 is placed in one of the sixteen small squares. Nine small squares have been filled in already.

The four numbers in each row of the complete magic square add up to 34.

The four numbers in each column add up to 34.

16			13
5	10		8
	6		
4	15		1

- (a) Use this information to copy and complete the magic square. [3]
- (b) From your completed square, describe four groups of four numbers, other than rows and columns, which add up to 34. [3]

26

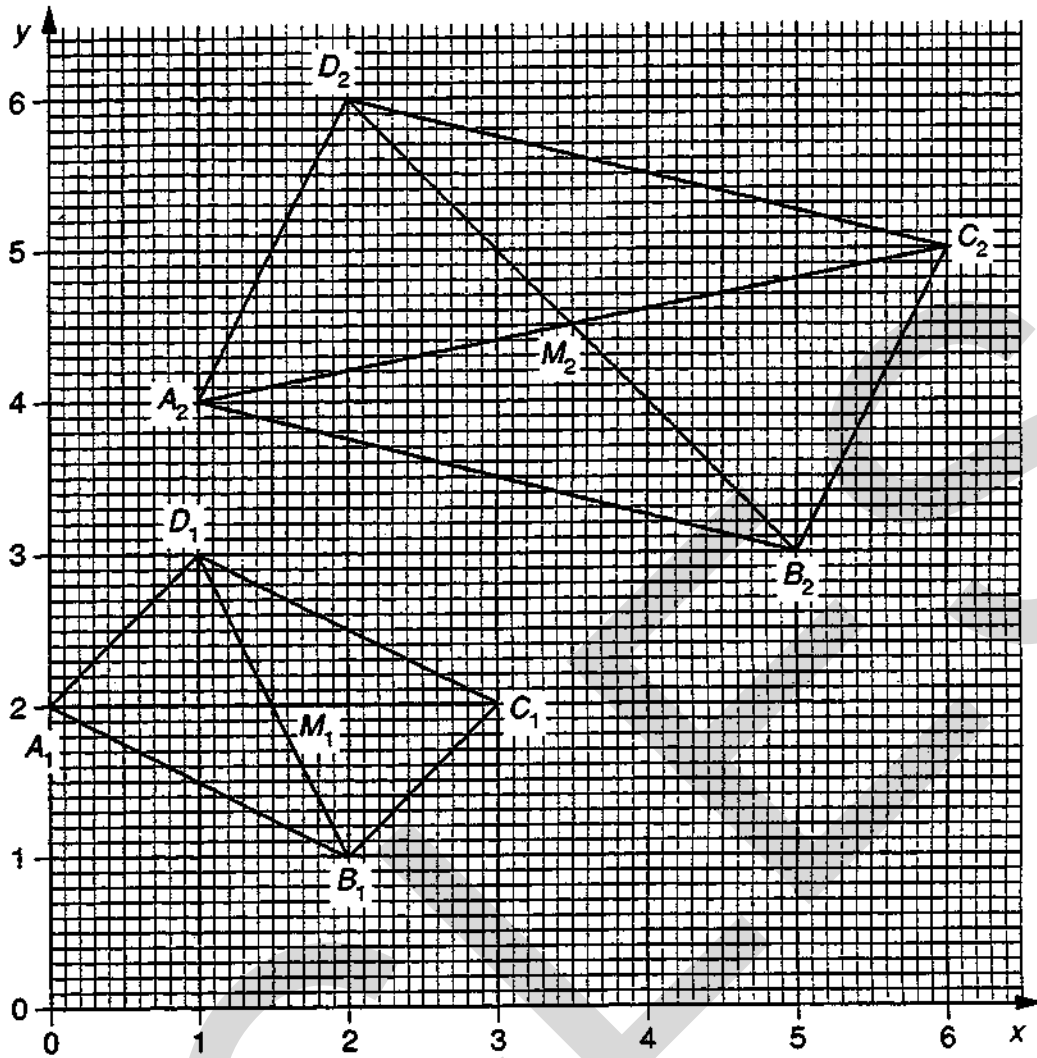

$A_1(0, 2)$	$C_1(3, 2)$	$M_1(1\frac{1}{2}, 2)$	$B_1(2, 1)$	$D_1(1, 3)$
$A_2(1, 4)$	$C_2(6, 5)$	$M_2(3\frac{1}{2}, 4\frac{1}{2})$	$B_2(5, 3)$	$D_2(2, 6)$
$A_3(4, 2)$	$C_3(6, 2)$		$B_3(6, 1)$	$D_3(4, 3)$
$A_4(3, 6)$	$C_4(5, 5)$		$B_4(1, 8)$	$D_4(7, 3)$

The first two lines of the table show the coordinates of opposite pairs of vertices of two parallelograms and the coordinates of  $M_1$  and  $M_2$  where the diagonals cross.

The next two lines show the coordinates of opposite pairs of vertices of two more parallelograms.

- (a) Find the coordinates of  $M_3$  and  $M_4$ . [3]
- (b) What is the relationship between the coordinates of the opposite vertices of a parallelogram and the coordinates of the point where the diagonals cross? [2]
- (c) Suggest a reason for your answer to part (b). [1]

- 27 (a) (i) Use your calculator to change  $\frac{14}{33}$  into a decimal.
- (ii) If your calculator could show one hundred figures after the decimal point, what would the 99th figure be?

Explain your answer.

[3]

- (b) Look at the following example which shows how to change the recurring decimal  $0.75757575 \dots$  into a fraction.

Step 1: Multiply by 100

Step 2: Subtract  $x$

Step 3: Solve the equation

$$x = 0.75757575 \dots$$

$$100x = 75.75757575 \dots$$

$$99x = 75$$

$$x = \frac{75}{99}$$

$$= \frac{25}{33}$$

$$\text{Answer } 0.757575 \dots = \frac{25}{33}$$

Follow the same steps to change the recurring decimal  $0.51515151 \dots$  into a fraction.

[3]

- (c) Could the same method be used to change  $0.123123123 \dots$  into a fraction?

Explain any amendments you would make at Steps 1, 2 or 3.

[3]

- 28 (a) Find the values of  $x$  and  $y$  to complete the following equations.

$$3^2 + 4^2 = x^2$$

$$3^3 + 4^3 + 5^3 = y^3$$

[2]

- (b) (i) What do you think the next line of the pattern should read?

[1]

- (ii) Showing your working, check whether your answer to part (b) (i) is correct.

[2]

- (c) (i) Without using a calculator, explain why  $3^5$  is an odd number.

[1]

- (ii) By considering powers of odd and even numbers, explain, without using a calculator, why

$$3^5 + 4^5 + 5^5 + 6^5 + 7^5 \text{ cannot equal } 8^5.$$

[3]

Centre Number	Candidate Number

Candidate Name \_\_\_\_\_

**MIDLAND EXAMINING GROUP**  
**General Certificate of Secondary Education**  
**MATHEMATICS (without Course Work)**  
**PAPER 3 (Further Tier)**

**1660/3**

Tuesday                      **7 JUNE 1994**                      Afternoon                      2 hours 30 minutes

- Additional materials:  
Answer paper  
Graph paper (1 sheet)  
Electronic calculator  
Geometrical instruments  
Tracing paper (optional)

**TIME** 2 hours 30 minutes

**INSTRUCTIONS TO CANDIDATES**

Write your name, Centre number and candidate number in the spaces at the top of this page and on all separate answer paper used.

Show all your working. Marks may be given for working which shows that you know how to solve the problem, even if you get the answer wrong.

**Section A**

Answer all questions.

Write your answers in the spaces provided on the question paper.

**Section B**

Answer all questions.

Write your answers on the writing and graph paper provided.

At the end of the examination, fasten the separate answer paper securely to the question paper, with the question paper on top of the answer paper.

**INFORMATION FOR CANDIDATES**

The number of marks is given in brackets [ ] at the end of each question or part question.

You are expected to use an electronic calculator for this paper.

Unless otherwise instructed in the question, take  $\pi$  to be 3.142 or use the  $\pi$  button on your calculator.

<b>FOR EXAMINER'S USE</b>

**This question paper consists of 28 printed pages.**

## INFORMATION AND FORMULAE

### MENSURATION

Parallelogram

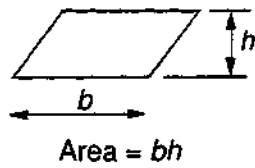

Trapezium

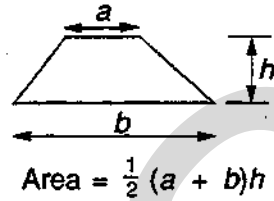
Cylinder (radius  $r$ , height  $h$ )Area of curved surface =  $2\pi rh$ Sphere (radius  $r$ )Volume =  $\frac{4}{3}\pi r^3$   
Area of surface =  $4\pi r^2$ 

Prism (including cylinder)

Volume = area of cross-section  $\times$  length

Pyramid (including cone)

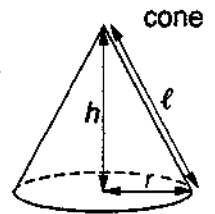
Volume =  $\frac{1}{3} \times$  area of base  $\times$  heightCone (radius  $r$ , height  $h$ )Area of curved surface =  $\pi r\ell$   
where  $\ell$  = slant height =  $\sqrt{h^2 + r^2}$ 

### TRIGONOMETRY

Right-angled triangle

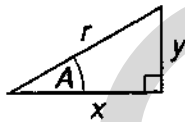
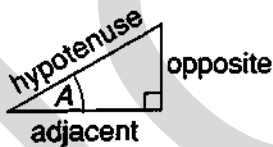
 $r^2 = x^2 + y^2$ , (result of Pythagoras) $x = r \cos A$ ,  $y = r \sin A$ ,  $y = x \tan A$  $\sin A = \frac{\text{opposite}}{\text{hypotenuse}}$ ,  $\cos A = \frac{\text{adjacent}}{\text{hypotenuse}}$ ,  $\tan A = \frac{\text{opposite}}{\text{adjacent}}$ 

Any triangle

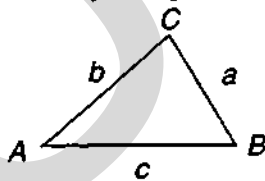
In any triangle  $ABC$ :  $\frac{a}{\sin A} = \frac{b}{\sin B} = \frac{c}{\sin C}$  $a^2 = b^2 + c^2 - 2bc \cos A$  $\cos A = \frac{b^2 + c^2 - a^2}{2bc}$ Area of triangle  $ABC = \frac{1}{2} ab \sin C$ NUMBER Standard form is  $a \times 10^n$  where  $1 \leq a < 10$  and  $n$  is an integer.Compound Interest formula  $A = P \left(1 + \frac{r}{100}\right)^n$ ALGEBRA The quadratic equation  $ax^2 + bx + c = 0$  has solutions

$$x = \frac{-b \pm \sqrt{b^2 - 4ac}}{2a}$$

**SECTION A**

Answer all questions in this section.

Write your answers in the spaces provided on the question paper.

Show all your working.

- 1 (a) List all the integers which satisfy

$$-2 < n \leq 3$$

.....  
.....

Answer (a) \_\_\_\_\_ [3]

- (b) Ajaz said, 'I thought of an integer, multiplied it by 3 then subtracted 2. The answer was between 47 and 62.'

List the integers that Ajaz could have used.

.....  
.....

Answer (b) \_\_\_\_\_ [3]

- 2 (a) A parcel is weighed on digital scales which record weight correct to the nearest one pound. The scales record 12 pounds.

What is the least possible weight of the parcel?

Answer (a) \_\_\_\_\_ pounds [1]

- (b) (i) Convert 12.35 pounds to kilograms, taking 1 kg to be 2.2 pounds.

Write down all the figures shown on your calculator display.

.....

.....

.....

Answer (b) (i) \_\_\_\_\_ kg

- (ii) Write down your answer to part (b) (i) correct to the nearest kilogram.

Answer (b) (ii) \_\_\_\_\_ kg [3]

- (c) A second parcel is weighed on the digital scales and its weight is also recorded as 12 pounds.

When the scales are set to record weights in kilograms, correct to the nearest kilogram, the weights shown for the parcels are not the same.

Suggest a possible reason for this.

.....

.....

.....

Answer (c) \_\_\_\_\_

\_\_\_\_\_

\_\_\_\_\_

\_\_\_\_\_ [2]

- 3 The table below gives information about the expected lifetimes, in hours, of 200 light bulbs.

Lifetime ( $t$ )	$0 < t \leq 400$	$400 < t \leq 800$	$800 < t \leq 1200$	$1200 < t \leq 1600$	$1600 < t \leq 2000$
Frequency	32	56	90	16	6

- (a) Mr Jones buys one of the light bulbs. What is the probability that it will last at least 800 hours but not more than 1600 hours?

.....

.....

Answer (a) \_\_\_\_\_ [3]

- (b) Using the given axes, draw a frequency polygon to illustrate the information in the table.

Answer (b)

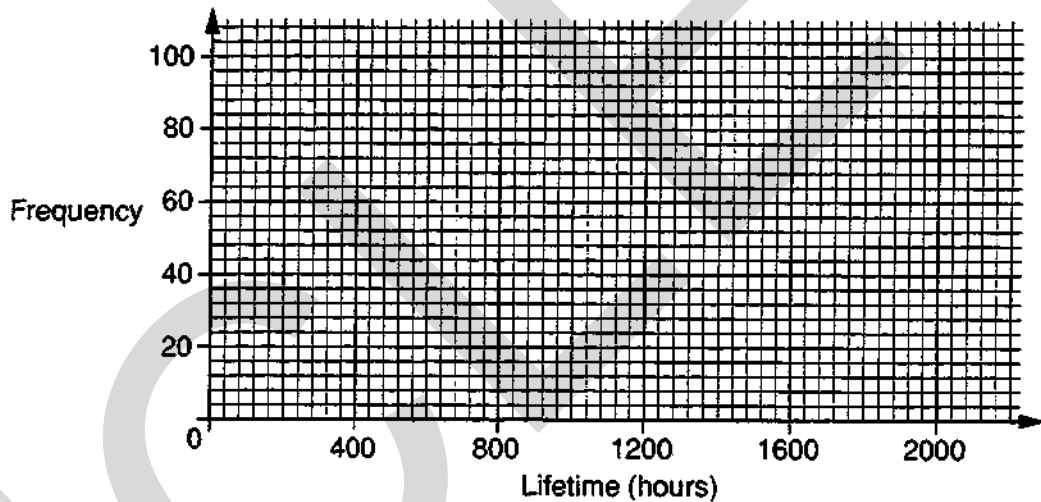

[3]



- 4 (a) Factorise completely  $12p^2q - 15pq^2$ .

.....  
.....  
.....

Answer (a) \_\_\_\_\_ [2]

- (b) Expand and simplify  $(2x - 3)(x + 5)$ .

.....  
.....  
.....

Answer (b) \_\_\_\_\_ [2]

- (c) The cost,  $C$  pence, of printing  $n$  party invitations is given by

$$C = 120 + 40n.$$

Find a formula for  $n$  in terms of  $C$ .

.....  
.....  
.....

Answer (c) \_\_\_\_\_ [2]

- 5 A child builds a tower from three similar cylindrical blocks. The smallest block, *A*, has radius 2.5 cm and height 6 cm.

NOT  
TO  
SCALE

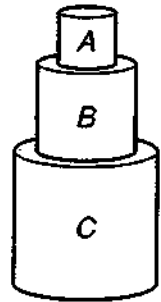

- (a) Find the volume of the smallest block.

.....

.....

.....

Answer (a) \_\_\_\_\_ cm<sup>3</sup> [3]

- (b) Block *B* is an enlargement of *A* and block *C* is an enlargement of *B*, each with a scale factor of  $1\frac{3}{4}$ .

Find the total height of the tower.

.....

.....

.....

Answer (b) \_\_\_\_\_ cm [3]

6

8

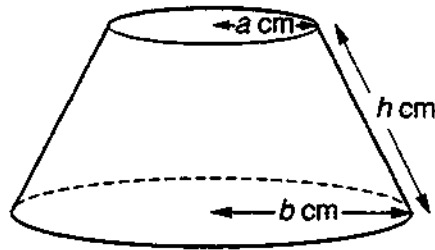

NOT TO  
SCALE

One of the formulae in the list below can be used to calculate the area of material needed to make the curved surface of the lampshade in the diagram.

- (i)  $\pi h(a + b)^2$
- (ii)  $\pi h^2(a + b)$
- (iii)  $\pi h(a + b)$
- (iv)  $\pi h^2(a + b)^2$

State which formula is correct. Give a reason for your answer.

.....

.....

Answer Formula is \_\_\_\_\_

because \_\_\_\_\_

\_\_\_\_\_

\_\_\_\_\_ [3]

7

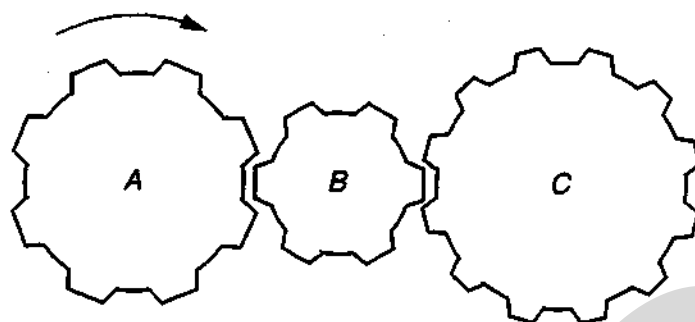

The diagram shows three interlocking cog wheels.

Wheel A has 8 cogs.

Wheel B has 6 cogs.

Wheel C has 12 cogs.

(a) Wheel A turns clockwise. In which direction does wheel B turn?

Answer (a) \_\_\_\_\_ [1]

(b) Wheel A makes 3 complete revolutions.

(i) How many complete revolutions does wheel B make?

.....  
 .....

Answer (b) (i) \_\_\_\_\_ [1]

(ii) How many complete revolutions does wheel C make?

.....  
 .....

Answer (b) (ii) \_\_\_\_\_ [1]

8 Alan, Barbara and Chris usually travel on the same bus to school.

- (a) Complete the following table by listing all the possible outcomes of Alan (*A*), Barbara (*B*) and Chris (*C*) trying to catch the bus. Use a tick to indicate 'catches the bus' and a cross to indicate 'does not catch the bus'.

Answer (a)

<i>A</i> ✓	<i>B</i> ✓	<i>C</i> ✓
<i>A</i> ✓	<i>B</i> ✓	<i>C</i> ✗

[2]

- (b) On any one day, the probability that Alan catches the bus is 0.8,  
the probability that Barbara catches the bus is 0.9 and  
the probability that Chris catches the bus is 0.75.

Calculate the probability that at least two of the three pupils catch the bus on any one day.

.....

.....

.....

Answer (b) \_\_\_\_\_ [4]

- 9 The formula to convert temperatures from degrees Fahrenheit ( $^{\circ}F$ ) into degrees Celsius ( $^{\circ}C$ ) is

$$C = \frac{5}{9} (F - 32).$$

Calculate the temperature in degrees Celsius which is equivalent to a temperature of  $-7^{\circ}F$ .

.....

.....

.....

Answer \_\_\_\_\_  $^{\circ}C$  [2]

10

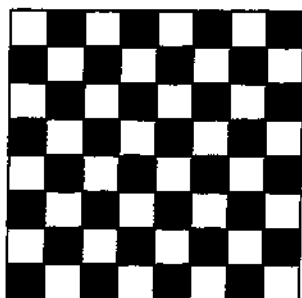

Centuries ago, a man promised to give his wife some grains of rice.

He took a chess board and placed one grain on the first square, two grains on the second square, four grains on the third square, eight grains on the fourth square, and so on.

If he had completed all 64 squares on the chessboard he would have used approximately  $1.845 \times 10^{19}$  grains of rice.

One grain of rice weighs about 0.01 grams.

Calculate an estimate of the weight of rice used.

Give your answer in tonnes, correct to one significant figure.

[1 tonne = 1000 kg.]

.....

.....

.....

Answer \_\_\_\_\_ tonnes [4]

11 (a) Write down the irrational numbers from the following list.

$$144^{\frac{1}{2}}, 72^{\frac{1}{2}}, 36^{\frac{1}{2}}, 18^{\frac{1}{2}}, 9^{\frac{1}{2}}$$

.....

.....

Answer (a) \_\_\_\_\_ [2]

(b) The midpoints of the sides of a square of side 12 cm are joined to form another square. The process is repeated so that a nest of five squares is formed.

Each square is labelled at one vertex only.

The area of square B is half the area of square A.

The area of square C is half the area of square B and so on.

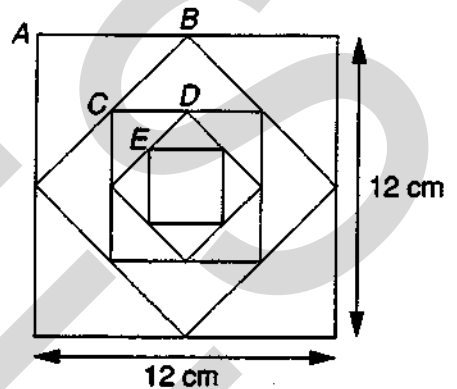

(i) Calculate the perimeter of square C.

.....

.....

Answer (b) (i) \_\_\_\_\_ cm

(ii) Is the perimeter of square D rational or irrational?  
Explain your answer.

.....

.....

Answer (b) (ii) \_\_\_\_\_

\_\_\_\_\_

\_\_\_\_\_

[3]

12

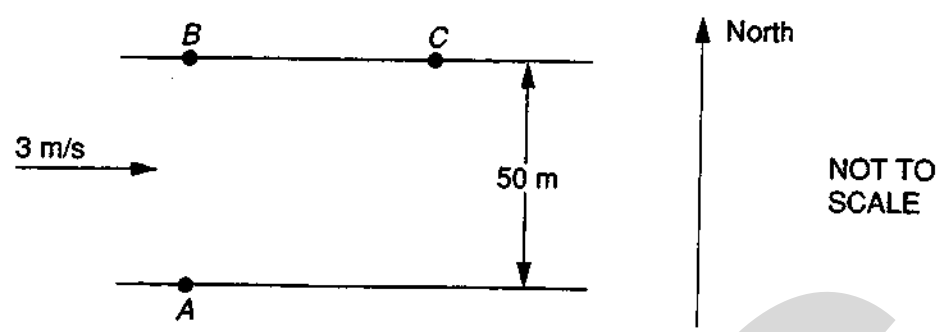

A river with parallel banks 50 m apart flows at a speed of 3 m/s from West to East. A girl can swim in still water with a speed of 1.6 m/s. She starts from A and intends to swim to B, which is due North of A and on the opposite bank. She heads North all the time but lands at C, further down stream.

Calculate the distance BC.

.....

.....

.....

.....

Answer \_\_\_\_\_ m [4]



- 13 The time of swing,  $T$  seconds, of a pendulum is proportional to the square root of the length,  $L$  centimetres, of the pendulum.

A pendulum of length 64 cm has a time of swing 1.6 seconds.

Find the formula for  $T$  in terms of  $L$ .

.....

.....

.....

.....

Answer \_\_\_\_\_ [5]

- 14 A bus company attempted to estimate the number of people who travel on local buses in a certain town. They telephoned 100 people in the town one evening and asked 'Have you travelled by bus in the last week?'

Nineteen people said 'Yes'. The bus company concluded that 19% of the town's population travel on local buses.

Give 3 criticisms of this method of estimation.

Answer \_\_\_\_\_

\_\_\_\_\_

\_\_\_\_\_

\_\_\_\_\_

\_\_\_\_\_

\_\_\_\_\_

[4]

15 Brian enjoys swimming.

If it is a sunny day the probability that he swims is 0.9.

If the day is not sunny, the probability that he swims is 0.65.

The probability that tomorrow will be sunny is 0.8.

(a) In the space below draw a tree diagram to illustrate this information.

Answer (a)

[2]

(b) Calculate the probability that Brian will not swim tomorrow.

.....

.....

.....

Answer (b) \_\_\_\_\_ [3]

- 16 (a) 33 children were asked, 'How many children are there in your family?' Their replies are shown in the following table

Number of children in family	1	2	3	4
Frequency	7	11	13	2

Darren and Fiona each worked out the mean number of children in a family.

Darren's answer was 2.3 children and Fiona's answer was 2.30 children.

Comment on the difference between these two answers.

.....

.....

.....

Answer (a) \_\_\_\_\_

[2]

- (b) The table below gives the ages in completed years of 33 children in a nursery school.

Age (completed years)	1	2	3	4
Frequency	7	11	13	2

Use Darren's answer in part (a) to obtain an estimate of the mean age, in years, of the 33 children.

.....

.....

.....

Answer (b) \_\_\_\_\_ years [2]

17  $OABC$  is a parallelogram.

$$\vec{OA} = 3\mathbf{p} - 2\mathbf{q}$$

$$\vec{OC} = 5\mathbf{p} + 6\mathbf{q}$$

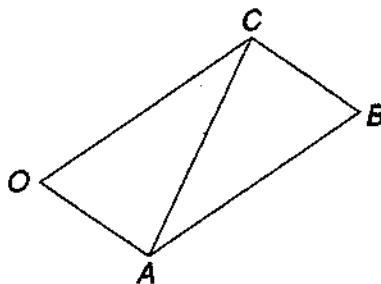

(a) Find  $\vec{AC}$ . Express your answer as simply as possible in terms of  $\mathbf{p}$  and  $\mathbf{q}$ .

.....

.....

Answer (a) \_\_\_\_\_ [2]

(b)  $D$  is the point where  $\vec{BD} = -2\mathbf{p} + 6\mathbf{q}$ .

Using vector methods, show that  $D$  lies on the line  $AC$  produced.

.....

.....

.....

Answer (b) \_\_\_\_\_

.....

.....

[3]

18

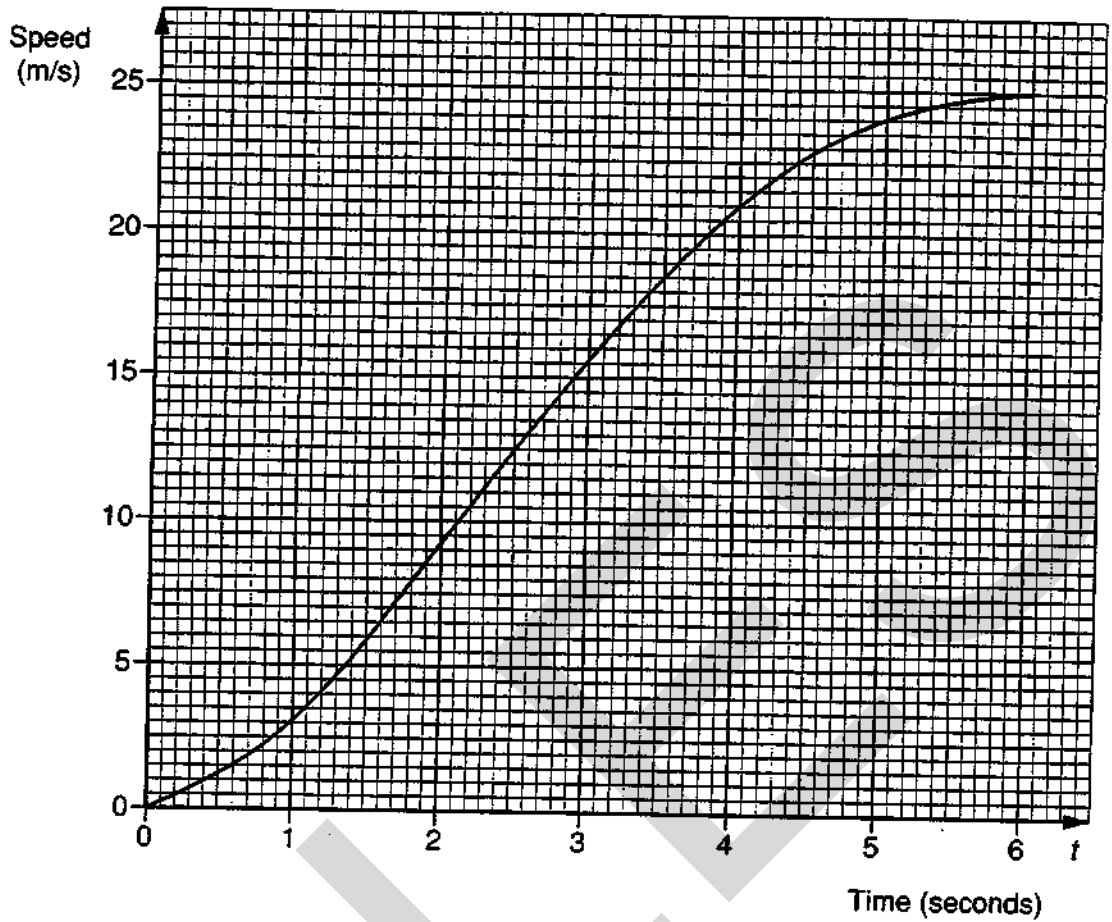

The graph shows how a car's speed, measured in metres per second, varies in the first 6 seconds after the car moves away from some traffic lights.

- (a) (i) Draw the tangent at the point on the curve where  $t = 5$  seconds.  
 (ii) Find the gradient of this tangent.

.....  
 .....

Answer (a) (ii) \_\_\_\_\_

- (iii) What does this gradient represent?

Answer (a) (iii) \_\_\_\_\_

[4]

(b) Making your method clear, estimate the area beneath the graph between  $t = 0$  and  $t = 6$ . Hence estimate the distance travelled by the car in the first 6 seconds.

.....

.....

.....

.....

.....

.....

.....

.....

Answer (b) \_\_\_\_\_ m [5]

19

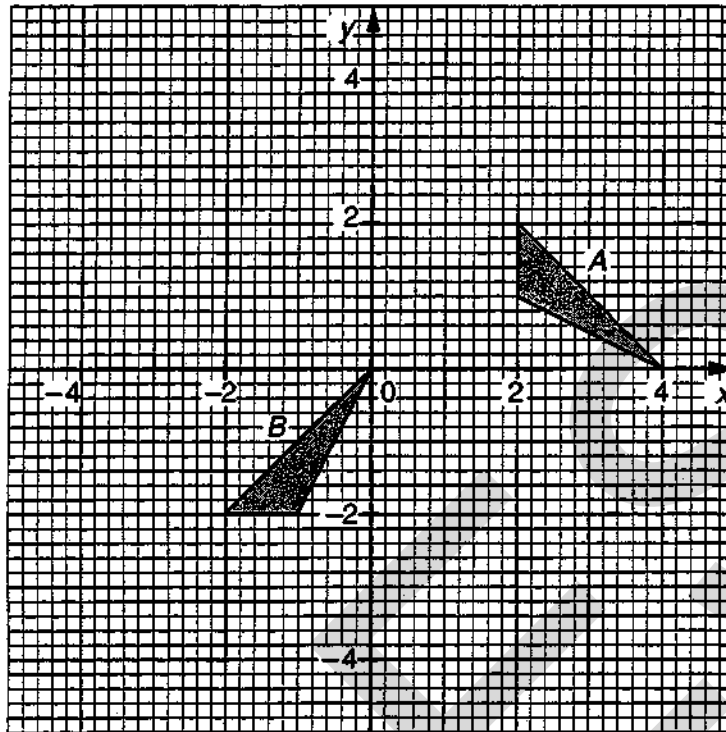

(a) Triangle *A* is mapped onto triangle *B* by means of an anticlockwise rotation centre the origin, followed by a translation.

(i) Write down the angle of rotation.

Answer (a) (i) \_\_\_\_\_

(ii) Find the matrix which represents this rotation.

.....  
 .....

Answer (a) (ii) \_\_\_\_\_

(iii) Find the column vector of the translation.

.....  
 .....

Answer (a) (iii) \_\_\_\_\_

[5]

- (b) Triangle  $A$  may be mapped onto triangle  $B$  by means of a single rotation. Find the coordinates of the centre of rotation.

.....  
.....

Answer (b) \_\_\_\_\_ [2]

- (c) Triangle  $B$  is reflected in the line  $y = -2$  to form triangle  $C$ . Describe the **single** transformation which would map triangle  $A$  onto triangle  $C$ .

.....  
.....

Answer (c) \_\_\_\_\_

\_\_\_\_\_ [2]



- 20 Mrs Brown's purse contains only fifty pence coins and pound coins.

On the graph below, the region  $ABCD$  (including the boundary) contains all the possible combinations  $(x, y)$  of 50p coins and £1 coins in Mrs Brown's purse.

$x$  is the number of 50p coins.

$y$  is the number of £1 coins.

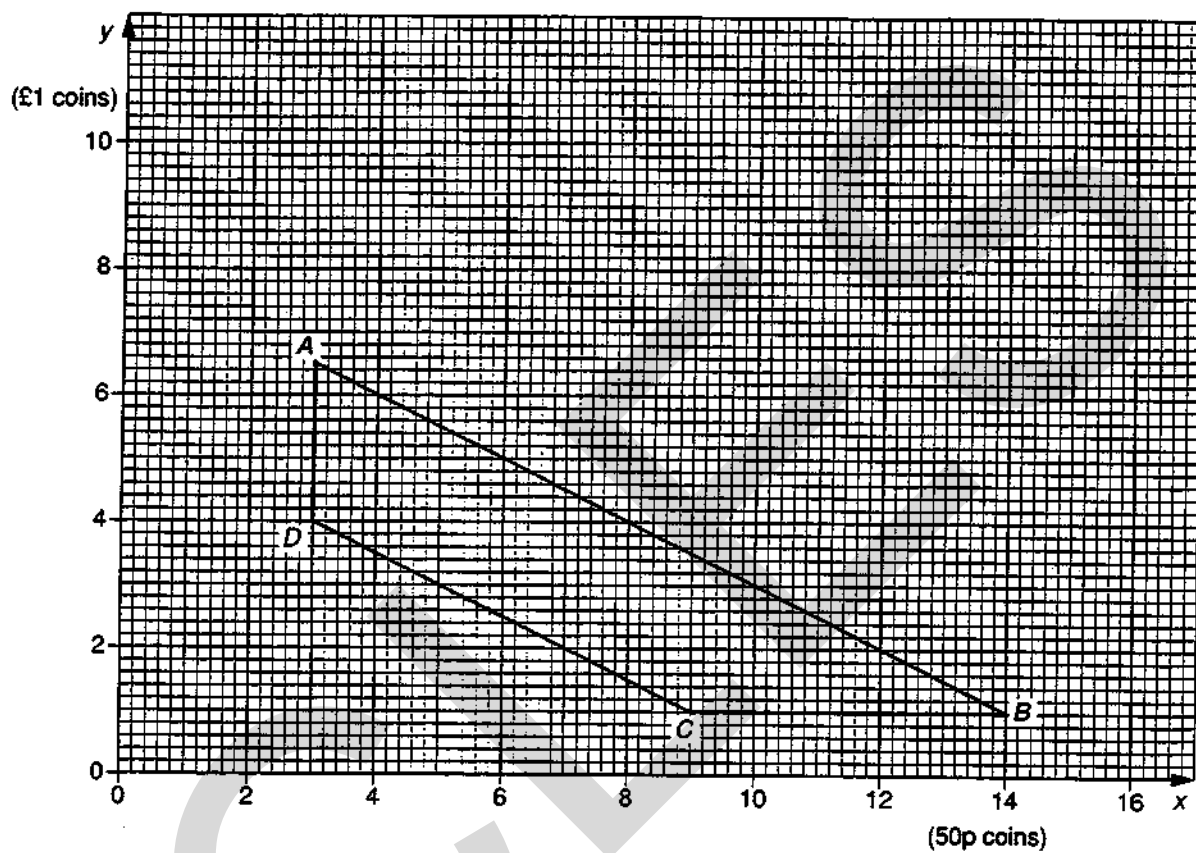

(a) (i) Write down the minimum possible number of 50p coins in the purse.

Answer (a) (i) \_\_\_\_\_

(ii) Find the maximum possible amount of money in the purse.

.....  
.....

Answer (a) (ii) £ \_\_\_\_\_

(iii) Find the minimum possible amount of money in the purse.

.....  
.....

Answer (a) (iii) £ \_\_\_\_\_

(iv) Use the graph to find the maximum possible number of coins in the purse.

.....  
.....

Answer (a) (iv) £ \_\_\_\_\_

[7]

(b) Mrs Brown now looks in her purse and notices that she has twice as many fifty pence coins as pound coins. How many pound coins could her purse contain?

.....  
.....

Answer (b) \_\_\_\_\_ [2]

21 On each of the grids below, the graph of  $y = f(x)$  for  $-4 \leq x \leq 4$  is drawn.

(a) On grid A, sketch the graph of  $y = 2f(x)$ .

GRID A

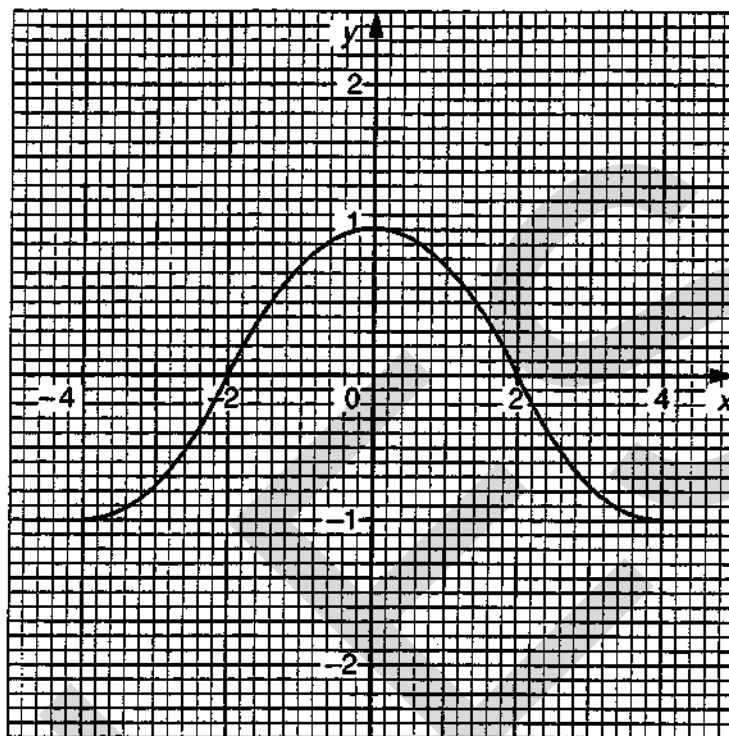

[2]

(b) On grid B, sketch the graph of  $y = f(x - 1)$ .

GRID B

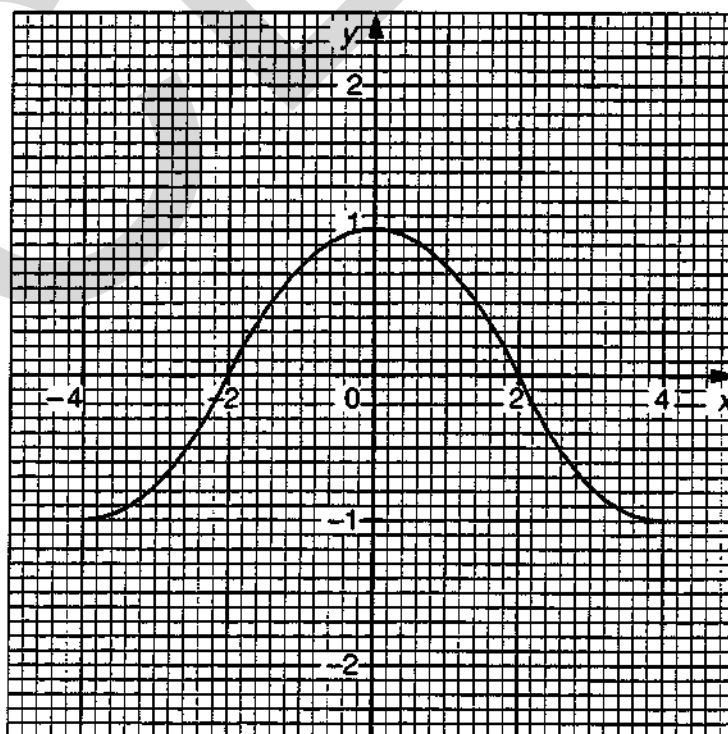

[2]

- 22 (a) A roll of dress material measures 23 metres, correct to the nearest metre. A shopkeeper cuts material of length 6 m 40 cm, correct to the nearest 10 cm, from the roll. What is the maximum possible length of material left on the roll?

.....

.....

.....

Answer (a) \_\_\_\_\_ m \_\_\_\_\_ cm [3]

- (b) Salma is doing an environmental science project about a park in her town. She uses a local map with a scale of 1 : 20 000 to estimate the distance from her home to the park and to estimate the area of the park.

- (i) Salma measures the map distance from her home to the park gate as 16.3 cm, correct to the nearest mm. Calculate, in kilometres, the minimum possible distance from Salma's home to the park gate.

.....

.....

.....

Answer (b) (i) \_\_\_\_\_ km

- (ii) The area representing the park on the map is 7 cm<sup>2</sup>, correct to the nearest cm<sup>2</sup>. Find the maximum possible area of the park in km<sup>2</sup>.

.....

.....

.....

Answer (b) (ii) \_\_\_\_\_ km<sup>2</sup>  
[6]

## SECTION B

Answer all questions in this section.

Write all your answers on the writing and graph paper provided.

Show all your working.

- 23 (a) Look at the following example which shows how to turn the recurring decimal 0.75757575.... into a fraction.

$$\begin{array}{l} x = 0.75757575\dots \\ \text{Step 1: Multiply by 100} \quad 100x = 75.75757575\dots \\ \text{Step 2: Subtract } x \quad 99x = 75 \\ \text{Step 3: Solve the equation} \quad x = \frac{75}{99} \\ \quad \quad \quad \quad \quad \quad \quad \quad x = \frac{25}{33} \end{array}$$

$$\text{Answer: } 0.75757575\dots = \frac{25}{33}$$

Follow the same steps to change the recurring decimal 0.51515151.... into a fraction. [3]

- (b) Could the same method be used to change 0.123123123.... into a fraction? Explain any amendments you would make at Steps 1, 2 or 3. [3]

- 24 It is known that

$$\begin{array}{l} 3^2 + 4^2 = 5^2 \\ 3^3 + 4^3 + 5^3 = 6^3 \end{array}$$

- (a) (i) What do you think the next line of the pattern should read?  
(ii) Showing your working, check whether your answer to part (a) (i) is correct. [2]
- (b) (i) Without using a calculator, explain why  $3^5$  is an odd number.  
(ii) By considering powers of odd and even numbers, explain, without using a calculator, why  $3^5 + 4^5 + 5^5 + 6^5 + 7^5$  cannot equal  $8^5$ . [4]

**25 You may use graph paper for this question.**

The table shows the Department of Transport statistics for road casualties in Great Britain for the years 1989–1990.

Q<sub>1</sub> represents the months January, February, March.

Q<sub>2</sub> represents the months April, May, June.

Q<sub>3</sub> represents the months July, August, September.

Q<sub>4</sub> represents the months October, November, December.

<b>Road casualties in Great Britain</b>		
<i>Total casualties</i>		
	<i>All ages</i>	<i>Under 15 years</i>
1989 Q <sub>1</sub>	77 828	9 364
Q <sub>2</sub>	83 305	11 865
Q <sub>3</sub>	87 747	12 209
Q <sub>4</sub>	92 712	9 603
1990 Q <sub>1</sub>	81 015	9 700
Q <sub>2</sub>	84 522	12 341
Q <sub>3</sub>	87 051	12 537
Q <sub>4</sub>	88 553	9 275

*Sources: Department of Transport;  
Scottish Development Department;  
Welsh Office*

(from *Monthly Digest of Statistics, September 1992*)

Prepare an analysis, with appropriate diagrams, suitable for a newspaper article highlighting the differences between the road casualty figures for children and adults at various times of the year. [9]

- 26 On the planet Quinque, arithmetic uses the digits  
0, 1, 2, 3 and 4 only.

The following calculating tables are used.

+	0	1	2	3	4
0	0	1	2	3	4
1	1	2	3	4	0
2	2	3	4	0	1
3	3	4	0	1	2
4	4	0	1	2	3

×	0	1	2	3	4
0	0	0	0	0	0
1	0	1	2	3	4
2	0	2	4	1	3
3	0	3	1	4	2
4	0	4	3	2	1

Use the tables to solve the equations

- (a) (i)  $a + 4 = 2$ ,  
(ii)  $2b + 4 = 2$ .

[3]

- (b) Using the tables and stating what assumptions you make,

- (i) solve  $c^2 = 4$ ,  
(ii) simplify  $1\frac{1}{3} \div \frac{3}{4}$ .

[6]

Centre Number	Candidate Number

Candidate Name \_\_\_\_\_

**MIDLAND EXAMINING GROUP**  
**General Certificate of Secondary Education**  
**MATHEMATICS (without Course Work)**  
**PAPER 4 (Basic Tier)**

**1660/4**

Friday                      **10 JUNE 1994**                      Morning                      2 hours

Candidates answer on the question paper.  
 Additional materials:  
 Electronic calculator  
 Geometrical instruments  
 Tracing paper (optional)

**TIME** 2 hours

**INSTRUCTIONS TO CANDIDATES**

Write your name, Centre number and candidate number in the spaces at the top of this page.

Answer **all** questions.

Write your answers in the spaces provided on the question paper.

Show all your working. Marks may be given for working which shows that you know how to solve the problem, even if you get the answer wrong.

**INFORMATION FOR CANDIDATES**

The number of marks is given in brackets [ ] at the end of each question or part question.

You are expected to use an electronic calculator for this paper.

Unless otherwise instructed in the question, take  $\pi$  to be 3.142 or use the  $\pi$  button on your calculator.

FOR EXAMINER'S USE

**This question paper consists of 22 printed pages and 2 blank pages.**



**MIDLAND EXAMINING GROUP**  
**General Certificate of Secondary Education**  
**MATHEMATICS (without Course Work)**  
**PAPER 4 (Basic Tier)**

**1660/4**

Friday

**10 JUNE 1994**

Morning

2 hours

**ERRATUM NOTICE**

**To be given to candidates**

In each of the following questions the first answer line should not be broken.

Page 6, Question 5 (a),

Answer (a) ( \_\_\_\_\_ , \_\_\_\_\_ ) should be printed as Answer (a) ( \_\_\_\_\_ , \_\_\_\_\_ )

Page 10, Question 9 (a),

Answer (a) A ( \_\_\_\_\_ , \_\_\_\_\_ ) should be printed as Answer (a) A ( \_\_\_\_\_ , \_\_\_\_\_ )

B ( \_\_\_\_\_ , \_\_\_\_\_ )

B ( \_\_\_\_\_ , \_\_\_\_\_ )

Page 10, Question 9 (d),

Answer (d) ( \_\_\_\_\_ , \_\_\_\_\_ ) should be printed as Answer (d) ( \_\_\_\_\_ , \_\_\_\_\_ )

# INFORMATION AND FORMULAE

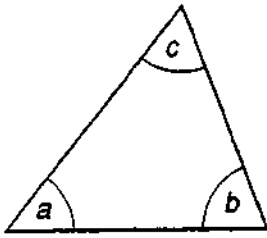

Angle sum of triangle  
 $a + b + c = 180^\circ$

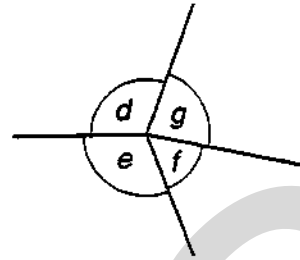

Angles at a point  
 $d + e + f = 360^\circ$

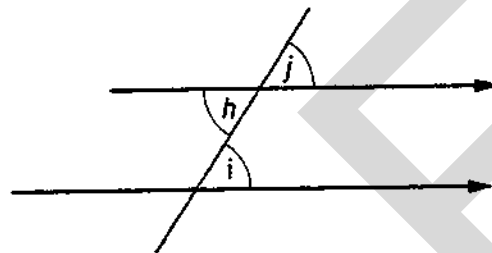

Parallel lines properties  
 $h = i$  and  $i = j$

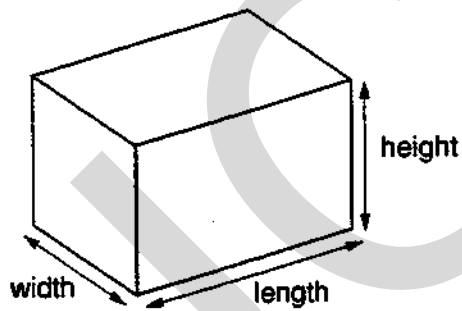

Volume of cuboid  
 $= \text{length} \times \text{width} \times \text{height}$

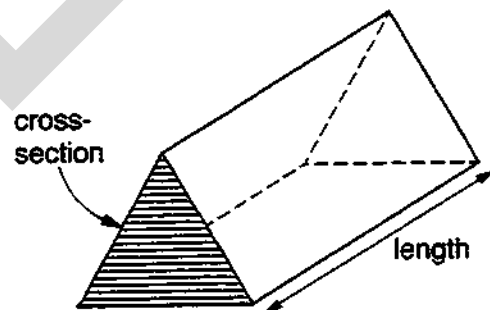

Volume of prism  
 $= \text{area of cross-section} \times \text{length}$

## SECTION A

Answer all questions in this section.

Show all your working.

- 1 68 sweets are shared equally between 9 children.  
Each child gets a whole number of sweets.

(a) How many sweets does each child get?

Answer (a) \_\_\_\_\_ [2]

(b) How many sweets are left over after the sharing has been completed?

Answer (b) \_\_\_\_\_ [2]

2

$$9 \times 2 = 18$$

$$9 \times 3 = 27$$

$$9 \times 4 = 36$$

$$9 \times 5 = 45$$

$$9 \times 6 = 54$$

$$9 \times 7 = 63$$

$$9 \times 8 = 72$$

$$9 \times 9 = 81$$

(a) (i) Complete the statement:

The units digits in the right-hand column, in order, are 8, 7, 6, \_\_\_\_\_

(ii) Complete the statement:

The tens digits in the right-hand column, in order, are 1, 2, 3, \_\_\_\_\_

(iii) What is the connection between the answers to parts (i) and (ii)?

Answer (a) (iii) \_\_\_\_\_

[2]

(b) The numbers in the right-hand column go up by 9 each time.

What else do you notice about these numbers?

Answer (b) \_\_\_\_\_

[2]

3

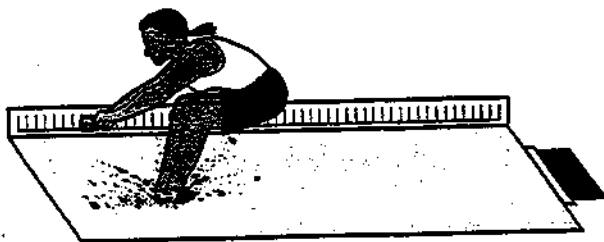

Six girls competed in the long jump at their school Sports Day. Their best jumps were as follows.

Anne	6.08 m
Beth	5.93 m
Candy	5.87 m
Donna	6.12 m
Emma	5.98 m
Fatima	

(a) Fatima finished in second place.

Write down a possible length for Fatima's jump.

Answer (a) \_\_\_\_\_ m [2]

(b) Arrange the six competitors in order of merit.

Answer (b) 1<sup>st</sup> \_\_\_\_\_

2<sup>nd</sup> Fatima.

3<sup>rd</sup> \_\_\_\_\_

4<sup>th</sup> \_\_\_\_\_

5<sup>th</sup> \_\_\_\_\_

6<sup>th</sup> \_\_\_\_\_ [3]

(c) Write down the length of Anne's jump in centimetres.

Answer (c) \_\_\_\_\_ cm [1]

- (d) Estimate the length of Anne's jump in feet.

Answer (d) \_\_\_\_\_ feet [2]

- (e) The long jump world record for women is 7.60 m.  
Express Anne's jump as a percentage of this world record.

.....  
Answer (e) \_\_\_\_\_ % [2]

4

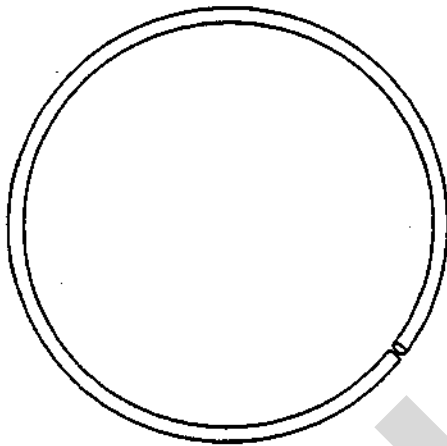

A piece of rope is 12 metres long. It is laid on the ground in a circle, as shown in the diagram.

- (a) Using 3.14 as the value of  $\pi$ , calculate the diameter of the circle.

.....  
.....  
.....  
Answer (a) \_\_\_\_\_ m [2]

- (b) Explain briefly how you would check the answer to part (a) mentally.

Answer (b) \_\_\_\_\_  
..... [2]

The cross-section of the rope is a circle of radius 1.2 cm.

- (c) Calculate the area of the cross-section.

.....  
.....  
Answer (c) \_\_\_\_\_ cm<sup>2</sup> [3]

- 5 Before planting some trees, a gardener marks two parallel lines,  $OP$  and  $XY$ , on the ground as shown in the diagram.
- He measures distances from the point  $O$ .
- He measures angles anticlockwise from the line  $OP$ .

SCALE : 1 cm represents 1m.

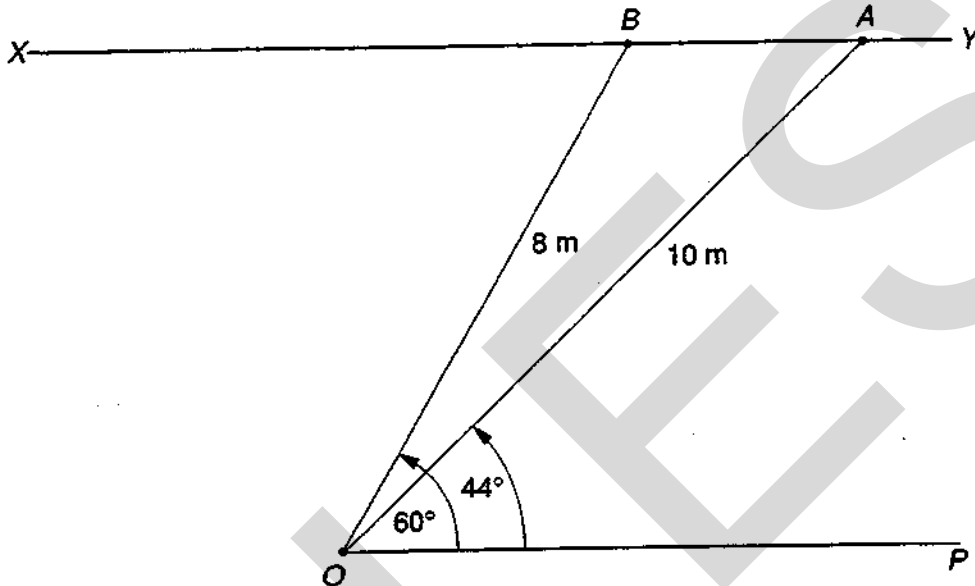

Tree  $A$  is planted 10 metres from  $O$ , with angle  $POA = 44^\circ$ .  
The position of tree  $A$  can be written  $(10, 44^\circ)$ .

- (a) Write down the position of the tree  $B$ , in the same way.

Answer (a) ( \_\_\_\_\_ , \_\_\_\_\_ ) [2]

- (b) On the diagram above, mark tree  $C$  whose position is  $(5, 90^\circ)$ . [2]

- (c) Tree  $D$  is to be planted on the line  $XY$ , 8 metres from  $B$  towards  $X$ .

- (i) Mark the position of tree  $D$  in the diagram.  
(ii) What special type of triangle is triangle  $OBD$ ?

Answer (c) (ii) \_\_\_\_\_

- (iii) Use the answer to part (c) (ii) to explain why the position of tree  $D$  is  $(8, 120^\circ)$ .

Answer (c) (iii) \_\_\_\_\_

\_\_\_\_\_

\_\_\_\_\_

[3]

6

7



When you put 3 in to this number machine, out comes 2.

(a) Fill in the missing numbers in the table below.

IN	OUT
3	2
5	<input type="text"/>
6	<input type="text"/>
<input type="text"/>	17

[3]

(b) Plot points on the grid below to represent your answers in part (a). The point (3, 2) has been plotted for you.

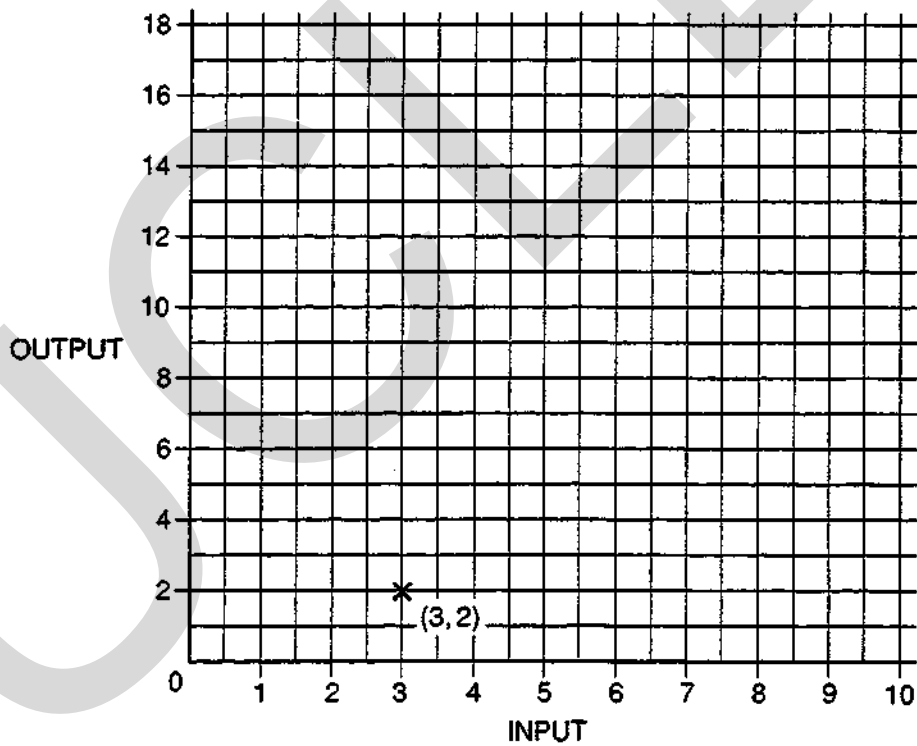

[2]

(c) What do you notice about the points that you have plotted?

Answer (c) \_\_\_\_\_

[1]

7

Monthly rainfall (millimetres)

	Jan	Feb	Mar	Apr	May	June	July	Aug	Sept	Oct	Nov	Dec
Great Britain	74	44	40	48	50	29	48	37	61	75	84	70
The Gambia	0	0	0	0	1	2	84	352	185	81	27	0

- (a) The mean rainfall per month in Great Britain is 55 mm.  
Calculate the mean rainfall per month in The Gambia.

.....

.....

.....

.....

Answer (a) \_\_\_\_\_ mm per month [3]

- (b) Find the range of the monthly rainfall  
(i) in The Gambia,

.....

Answer (b) (i) \_\_\_\_\_ mm [1]

- (ii) in Great Britain.

.....

Answer (b) (ii) \_\_\_\_\_ mm [2]

- (c) In which of these two countries are water shortages more likely?

Answer (c) \_\_\_\_\_ [1]

- (d) Explain your answer to part (c), using the means and the ranges.

Answer (d) \_\_\_\_\_

\_\_\_\_\_

\_\_\_\_\_

\_\_\_\_\_ [2]



(e) Monthly rainfall (millimetres)

	Jan	Feb	Mar	Apr	May	June	July	Aug	Sept	Oct	Nov	Dec
Geneva	48	46	56	64	76	79	74	91	90	71	79	

The table above shows the monthly rainfall figures for Geneva.

The figure for December is missing.

The diagram below represents the figures for all 12 months.

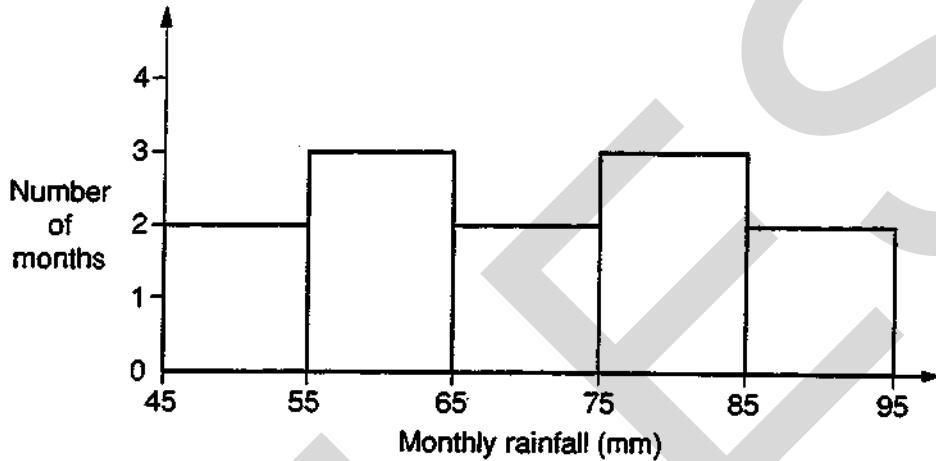

According to this diagram, in which class interval does the December rainfall lie?

Answer (e) \_\_\_\_\_ [2]

8 (a) Chocolate bars cost 24 pence each.

Write down a formula for the total cost,  $C$  pence, of  $n$  chocolate bars.

Answer (a)  $C =$  \_\_\_\_\_ [2]

(b) Given the table of values

$x$	1	2	3	4	5
$y$	4	5	6	7	8

write down the relation between  $x$  and  $y$  in the form  $y = \dots\dots\dots$

.....

.....

Answer (b)  $y =$  \_\_\_\_\_ [2]

- 9 (a) Two points  $A$  and  $B$  are shown on the grid below.  
Write down their coordinates.

Answer (a)  $A$  ( \_\_\_\_\_ , \_\_\_\_\_ )

$B$  ( \_\_\_\_\_ , \_\_\_\_\_ ) [2]

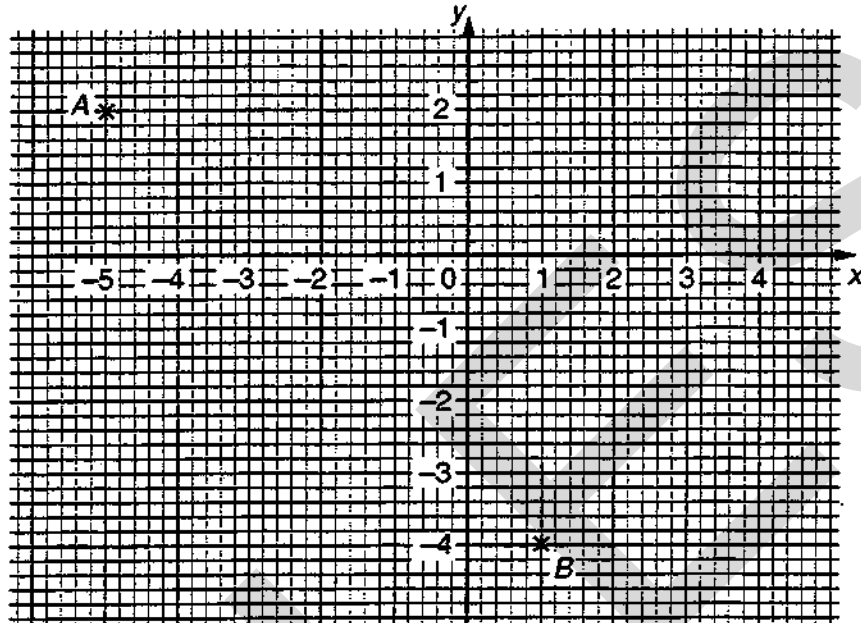

- (b) Complete the table of values below for

$$y = x - 2.$$

$x$	-2	0	2	3	4
$y$		-2			2

[2]

- (c) Draw the graph of  $y = x - 2$  on the grid above. [2]

- (d) On the grid, draw the straight line  $AB$ .

Write down the coordinates of the point where the graph of  $y = x - 2$  cuts the line  $AB$ .

Answer (d) ( \_\_\_\_\_ , \_\_\_\_\_ ) [1]

10

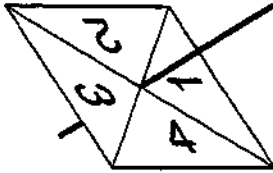

A spinner, with its edges numbered one to four, is biased.

For one spin, the probability of scoring 1 is 0.2,  
the probability of scoring 3 is 0.15  
and the probability of scoring 4 is 0.3.

- (a) Calculate the probability of scoring 2 with one spin.

.....  
Answer (a) \_\_\_\_\_ [3]

- (b) (i) Explain why the spinner is described as biased.

Answer (b) (i) \_\_\_\_\_ [1]

- (ii) If the spinner were fair, what could you say about the probabilities of each of the four possible scores?

Answer (b) (ii) \_\_\_\_\_ [2]

- (c) The spinner is spun twice.

- (i) Represent all the possible outcomes by crosses on the diagram below.

The outcome

First spin 2      Second spin 4

has been marked for you.

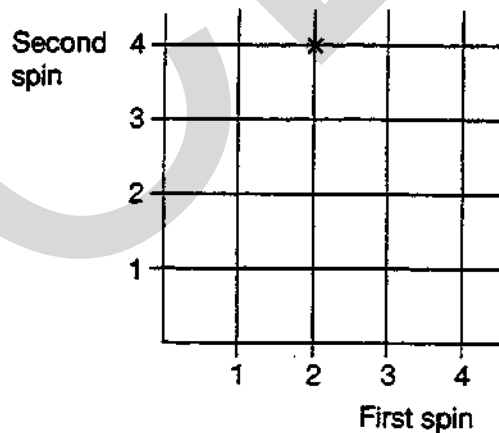

[2]

- (ii) Draw a ring round those crosses for which the total of the two spins is 6. [2]

11 The diagram below is the net of a small open box, with no top face.

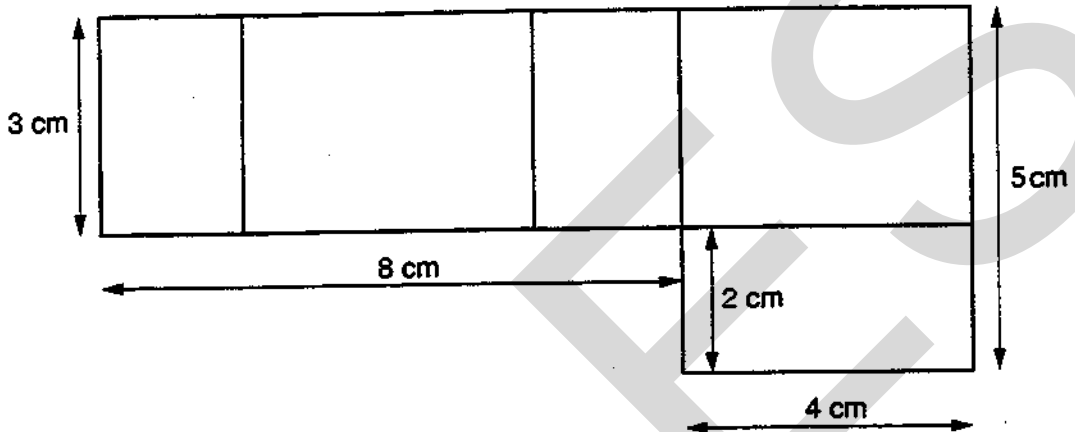

(a) Find the perimeter of the net.

.....  
 Answer (a) \_\_\_\_\_ cm [2]

(b) Calculate the area of the net.

.....  
 .....  
 Answer (b) \_\_\_\_\_ cm<sup>2</sup> [2]

(c) Add one more rectangle in a suitable position to change the diagram above to the net of a closed box. [2]

(d) Write down the length, width and height of the box (in any order).

Answer (d) \_\_\_\_\_ cm, \_\_\_\_\_ cm, \_\_\_\_\_ cm [2]

(e) Calculate the volume of the box.

.....  
 Answer (e) \_\_\_\_\_ cm<sup>3</sup> [2]

(f) Draw an isometric view of the closed box on the grid below.

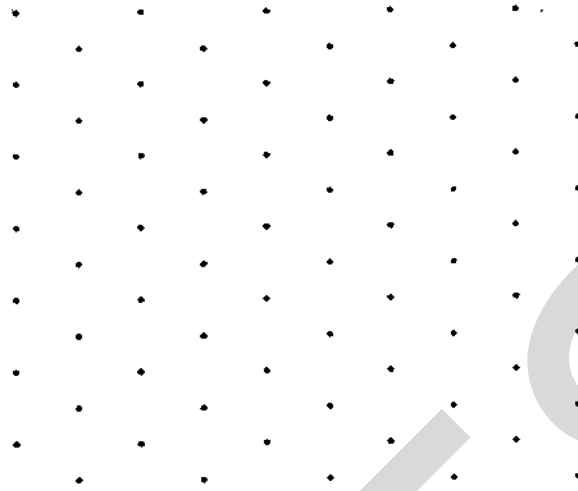

[3]

- 12 (a) The diagram shows a mineral water bottle.  
Draw the approximate water level on the bottle,  
if it is three-quarters full.

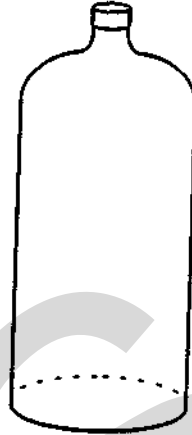

Answer (a) [2]

- (b) Bottles of mineral water cost 39p each.  
Estimate the cost of 142 bottles.  
Show how you obtained your estimate.

Answer (b) \_\_\_\_\_  
\_\_\_\_\_  
\_\_\_\_\_ [2]

- (c) Without using a calculator, work out the exact cost of 142 bottles of mineral water at 39p each.  
(You must write down enough working to show that you did not use a calculator).

Answer (c) \_\_\_\_\_  
\_\_\_\_\_  
\_\_\_\_\_  
\_\_\_\_\_  
\_\_\_\_\_  
\_\_\_\_\_  
\_\_\_\_\_  
\_\_\_\_\_ [3]

13 (a)

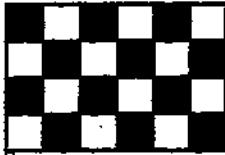

The area of each small square on the chequered flag is  $64 \text{ cm}^2$ .  
What is the area of the flag?

.....  
.....

Answer (a) \_\_\_\_\_  $\text{cm}^2$  [2]

(b)

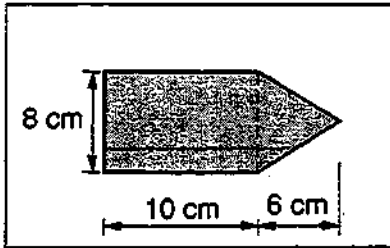

NOT TO SCALE

The design on this flag consists of a rectangle and a triangle.

(i) Calculate the area of the design.

.....  
.....  
.....  
.....

Answer (b) (i) \_\_\_\_\_  $\text{cm}^2$  [3]

(ii) The two parts of the flag are to be different colours.

The design is to be red or blue or white.

The outer part is to be red or blue or green.

List the possible pairs of colours of the two parts of the flag.

Answer (b) (ii)

Design	Outer Part

[3]

14 This question is about the way water is used in two Mozambique villages.

- (a) In village A, 324 litres of water are used each day.  
The pie chart below shows how the water is used.

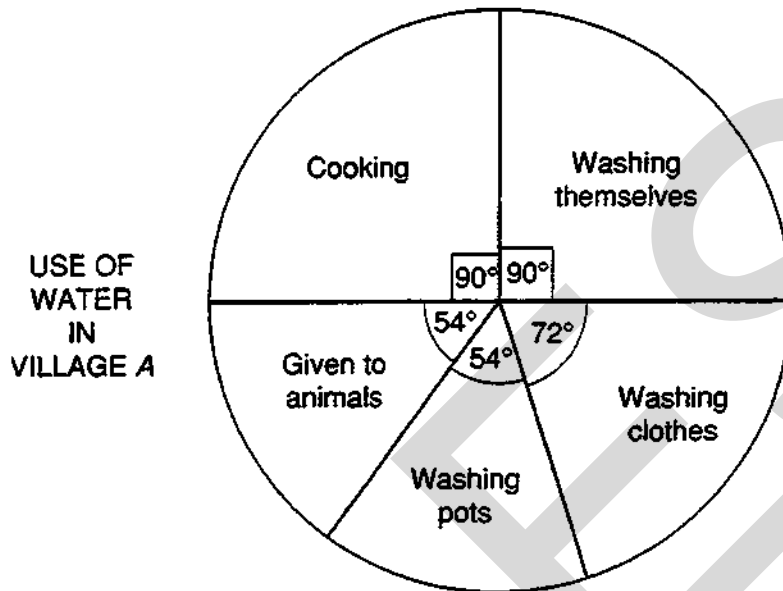

- (i) How much water (in litres) is used each day for cooking?

.....  
.....

Answer (a) (i) \_\_\_\_\_ litres [2]

- (ii) What fraction of the water used is given to animals?

.....  
.....

Answer (a) (ii) \_\_\_\_\_ litres [1]



(b) In village *B*, the water is used as follows:

Cooking	20%
Washing themselves	50%
Washing clothes	20%
Washing pots	10%

Using the circle below, represent this information in a pie chart.

.....

.....

.....

USE OF  
WATER  
IN  
VILLAGE *B*

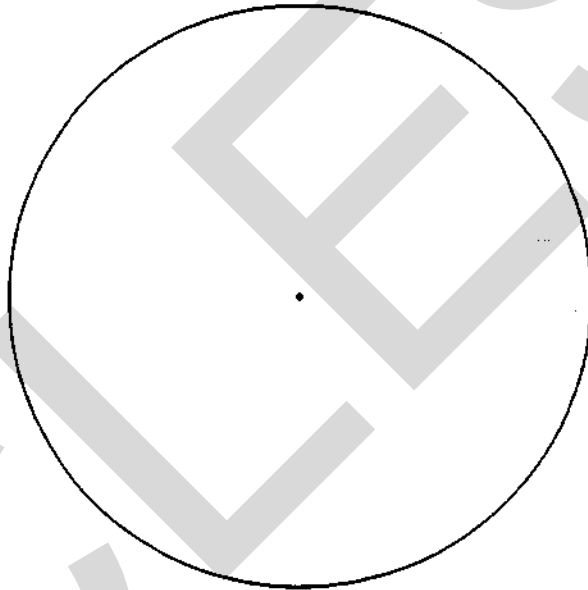

[3]

15 The usual price of a television set is £298 plus VAT at  $17\frac{1}{2}\%$ .

(a) (i) Work out the exact value of  $17\frac{1}{2}\%$  of £298.

.....  
 .....  
 .....  
 .....

Answer (a) (i) £ \_\_\_\_\_ [2]

(ii) What is the usual price of this television set?

.....

Answer (a) (ii) £ \_\_\_\_\_ [1]

**GANNET STORE  
 BARGAIN OFFER!  
 You pay no VAT!**

**BERRIES STORE  
 SALE!  
 $\frac{1}{6}$  OFF  
 USUAL PRICES**

Gannet Store and Berries Store are selling larger television sets at reduced prices. The usual price of these sets in both stores is £423 (£360 plus £63 VAT).

(b) (i) Calculate the difference between the reduced prices in the two stores. Show your working clearly.

.....  
 .....  
 .....  
 .....

Answer (b) (i) £ \_\_\_\_\_ [3]

(ii) Which of the stores gives the bigger reduction?

Answer (b) (ii) \_\_\_\_\_ [1]

16 The odd numbers are arranged in rows of five, as follows:

Row number ( $n$ )	First number in row ( $F$ )					Last number in row ( $L$ )
1	1	3	5	7	9	
2	11	13	15	17	19	
3	21	23	25	27	29	
	and so on.					

(a)

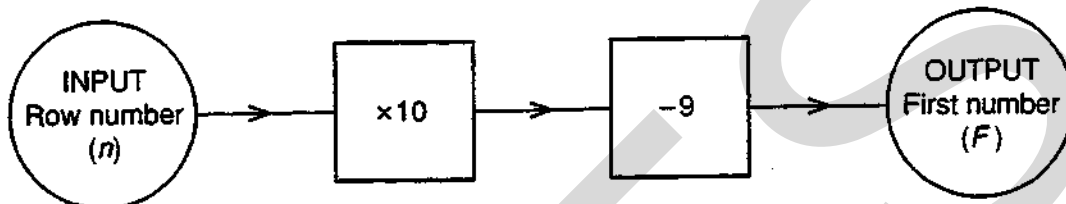

This number machine can be used to find the first number ( $F$ ) in row  $n$ .

The machine uses the rule  $F = 10n - 9$ .

(i) Complete the following number machine to give the last number ( $L$ ) in row number  $n$ .

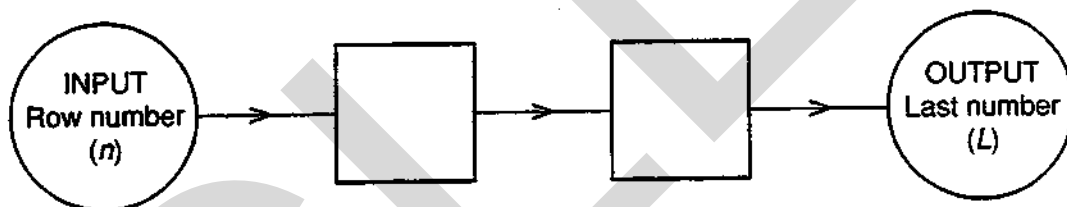

[2]

(ii) Write down the rule connecting  $L$  and  $n$ .

Answer (a) (ii) \_\_\_\_\_ [2]

(b) The numbers in Row 1 add up to 25.

(i) Complete the following table.

Row	1	2	3	4	5
Sum of numbers in the row	25				

[2]

(ii) Work out which row has a sum of 875.

.....  
 .....

Answer (b) (ii) Row \_\_\_\_\_ [1]

(iii) Explain how you obtained your answer to part (b) (ii).

Answer (b) (iii) \_\_\_\_\_  
 \_\_\_\_\_  
 \_\_\_\_\_ [2]

## SECTION B

Answer all questions in this section.

Show all your working.

- 17 This question is about polygons whose interior angles are either  $90^\circ$  or  $270^\circ$ . They will be called 'right polygons.'

A four-sided right polygon is a rectangle.

It has four  $90^\circ$  angles.



A six-sided right polygon is shown in the diagram.

It has five  $90^\circ$  angles and one  $270^\circ$  angle.

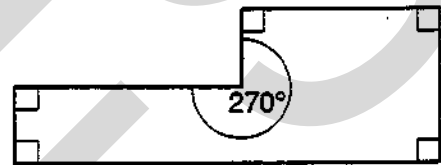

- (a) (i) Draw an eight-sided right polygon.

[4]

- (ii) How many  $90^\circ$  angles does your drawing have?

How many  $270^\circ$  angles does it have?

Answer (a) (ii) \_\_\_\_\_  $90^\circ$  angles

\_\_\_\_\_  $270^\circ$  angles [2]

- (b) What is the sum of (i) the four interior angles of a rectangle,

Answer (b) (i) \_\_\_\_\_ [1]

- (ii) the six interior angles of a six-sided right polygon,

Answer (b) (ii) \_\_\_\_\_ [1]

- (iii) the eight interior angles of an eight-sided right polygon?

Answer (b) (iii) \_\_\_\_\_ [1]

(c) Fill in the blanks in this table, for right polygons.

Number of sides	4	6	8	10	12
Number of $90^\circ$ angles	4	5	—	—	—
Number of $270^\circ$ angles	0	1	—	—	—
Sum of all angles	—	—	—	—	—

[6]

QUESTION 18 BEGINS ON PAGE 22

18 In this question an arrow means 'is a factor of' (or 'divides exactly into').

The 'Factor Diagram' on the right shows that 3 is a factor of 6, 12 and 15; that 5 is a factor of 15; and that 6 is a factor of 12.

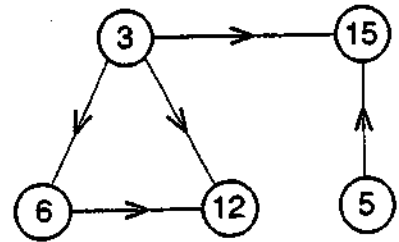

There is no line with an arrow connecting 6 and 15, and this means that 6 is not a factor of 15.

(a) Complete this Factor Diagram by putting in the arrows.



(b) In the empty circles in the Factor Diagram below, insert the six whole numbers (all different and all greater than 1) that are needed to complete this diagram correctly.

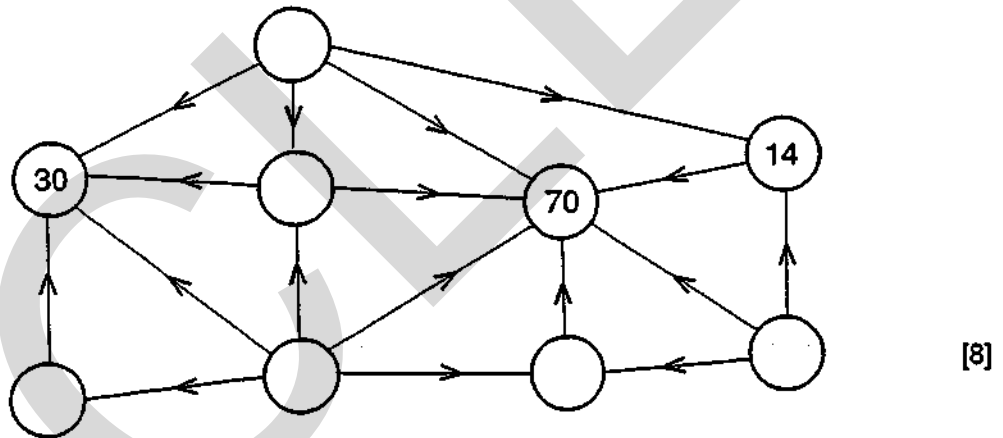

(c) Now make up your own Factor Diagram in the space below, using 20 as the largest number.

Centre Number      Candidate  
Number

Candidate Name \_\_\_\_\_

--	--

**MIDLAND EXAMINING GROUP**  
General Certificate of Secondary Education  
**MATHEMATICS (without Course Work)**  
PAPER 5 (Central Tier)

**1660/5**

Friday                      **10 JUNE 1994**                      Morning                      2 hours 30 minutes

Additional materials:  
Answer paper  
Graph paper (2 sheets)  
Electronic calculator  
Geometrical instruments  
Tracing paper (optional)

**TIME** 2 hours 30 minutes

**INSTRUCTIONS TO CANDIDATES**

Write your name, Centre number and candidate number in the spaces at the top of this page and on all separate answer paper used.

Show all your working. Marks may be given for working which shows that you know how to solve the problem, even if you get the answer wrong.

**Section A**

Answer all questions.

Write your answers in the spaces provided on the question paper.

**Section B**

Answer all questions.

Write your answers on the writing and graph paper provided.

At the end of the examination, fasten the separate answer paper securely to the question paper, with the question paper on top of the answer paper.

**INFORMATION FOR CANDIDATES**

The number of marks is given in brackets [ ] at the end of each question or part question.

You are expected to use an electronic calculator for this paper.

Unless otherwise instructed in the question, take  $\pi$  to be 3.142 or use the  $\pi$  button on your calculator.

<b>FOR EXAMINER'S USE</b>

**This question paper consists of 25 printed pages and 3 blank pages.**

# INFORMATION AND FORMULAE

## MENSURATION

Parallelogram

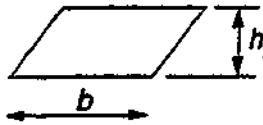

$$\text{Area} = bh$$

Trapezium

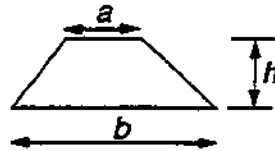

$$\text{Area} = \frac{1}{2} (a + b)h$$

Cuboid

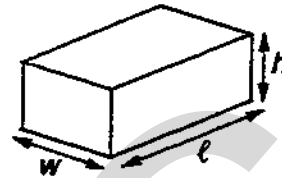

$$\text{Volume} = lwh$$

Prism  
eg triangular prism

$$\text{Volume} = \text{area of cross-section} \times \text{length}$$

cross-section



eg cylinder

cross-section

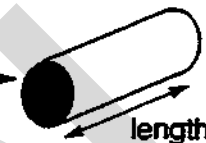

## TRIGONOMETRY

Right-angled triangle

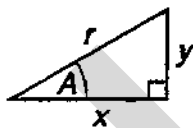

$$r^2 = x^2 + y^2, \text{ (result of Pythagoras)}$$

$$x = r \cos A, \quad y = r \sin A, \quad y = x \tan A$$

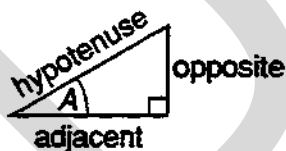

$$\sin A = \frac{\text{opposite}}{\text{hypotenuse}}, \quad \cos A = \frac{\text{adjacent}}{\text{hypotenuse}}, \quad \tan A = \frac{\text{opposite}}{\text{adjacent}}$$

## NUMBER

Standard form is  $a \times 10^n$  where  $1 \leq a < 10$  and  $n$  is an integer.



**SECTION A**

Answer all questions in this section.

Write your answers in the spaces provided on the question paper.

Show all your working.

1

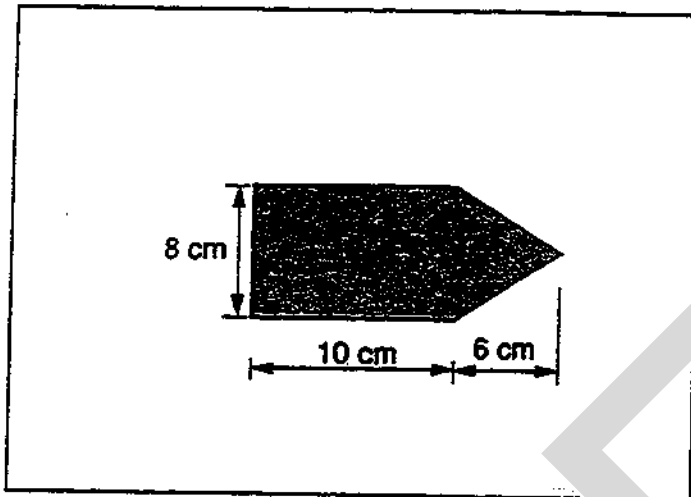

The diagram shows a flag.

The design on the flag consists of a rectangle and a triangle.

(a) Calculate the area of the design.

.....

.....

.....

.....

Answer (a) \_\_\_\_\_ cm<sup>2</sup> [3]

(b) The two parts of the flag are to be different colours.

The design is to be red or blue or white.

The outer part is to be red or blue or green.

List the possible pairs of colours of the two parts of the flag.

Answer (b)

Design	Outer Part

[3]

2 This question is about the way water is used in two Mozambique villages.

(a) In village A, 324 litres of water are used each day.

The pie chart below shows how the water is used.

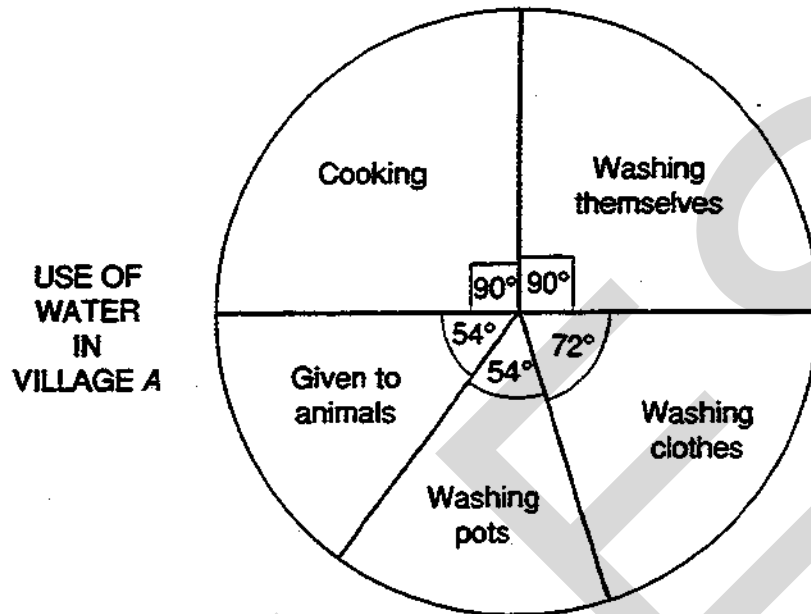

(i) How much water (in litres) is used each day for cooking?

.....

.....

Answer (a) (i) \_\_\_\_\_ litres [2]

(ii) What fraction of the water used is given to animals?

.....

.....

Answer (a) (ii) \_\_\_\_\_ [1]

(b) In village B, the water is used as follows:

Cooking	20%
Washing themselves	50%
Washing clothes	20%
Washing pots	10%

Using the circle below, represent this information in a pie chart.

.....

.....

.....

USE OF  
WATER  
IN  
VILLAGE B

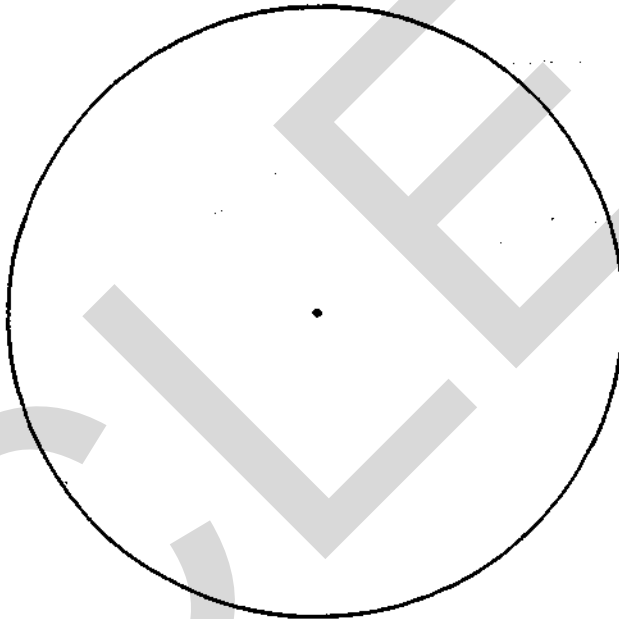

[3]

- 3 (a) Bottles of mineral water cost 39p each.  
Estimate the cost of 142 bottles.  
Show how you obtained your estimate.

Answer (a) \_\_\_\_\_

\_\_\_\_\_

[2]

- (b) Without using a calculator, work out the exact cost of 142 bottles of mineral water at 39p each.  
(You must write down enough working to show you did not use a calculator.)

Answer (b) \_\_\_\_\_

\_\_\_\_\_

\_\_\_\_\_

\_\_\_\_\_

\_\_\_\_\_

[3]

4 (a) The usual price of a television set is £298 plus VAT at  $17\frac{1}{2}\%$ .

(i) Work out the exact value of  $17\frac{1}{2}\%$  of £298.

.....

.....

.....

.....

Answer (a) (i) £ \_\_\_\_\_ [2]

(ii) What is the usual price of this television set?

.....

.....

Answer (a) (ii) £ \_\_\_\_\_ [1]

(b)



Gannet Store and Berries Store are selling larger television sets at reduced prices. The usual price of these sets in both stores is £423 (£360 plus £63 VAT).

(i) Calculate the difference between the reduced prices in the two stores. Show your working clearly.

.....

.....

.....

.....

Answer (b) (i) £ \_\_\_\_\_ [3]

(ii) Which of the stores gives the bigger reduction?

Answer (b) (ii) \_\_\_\_\_ [1]

5 The odd numbers are arranged in rows of five, as follows:

Row number ( $n$ )	First number in row ( $F$ )					Last number in row ( $L$ )
1	1	3	5	7	9	
2	11	13	15	17	19	
3	21	23	25	27	29	
	and so on.					

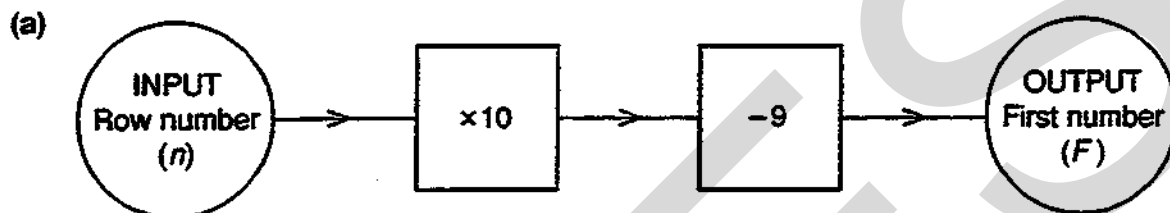

This number machine can be used to find the first number ( $F$ ) in row  $n$ .

The machine uses the rule  $F = 10n - 9$ .

(i) Complete the following number machine to give the last number ( $L$ ) in row  $n$ .

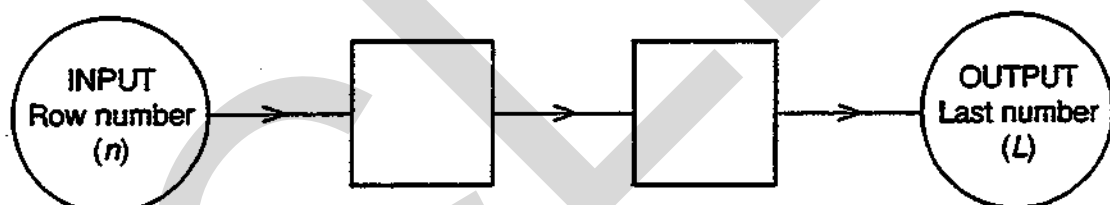

[2]

(ii) Write down the rule connecting  $L$  and  $n$ .

Answer (a) (ii) \_\_\_\_\_ [2]

(b) The numbers in Row 1 add up to 25.

(i) Complete the following table.

Row	1	2	3	4	5
Sum of numbers in the row	25				

[2]

(ii) Work out which row has a sum of 875.

.....

.....

Answer (b) (ii) \_\_\_\_\_ [1]

(iii) Explain how you obtained your answer to part (b) (ii).

Answer (b) (iii) \_\_\_\_\_

\_\_\_\_\_ [2]

(iv) The sum of the numbers in row  $n$  is denoted by  $S$ .

Find a formula for  $S$  in terms of  $n$ .

.....

.....

Answer (b) (iv) \_\_\_\_\_ [3]

6

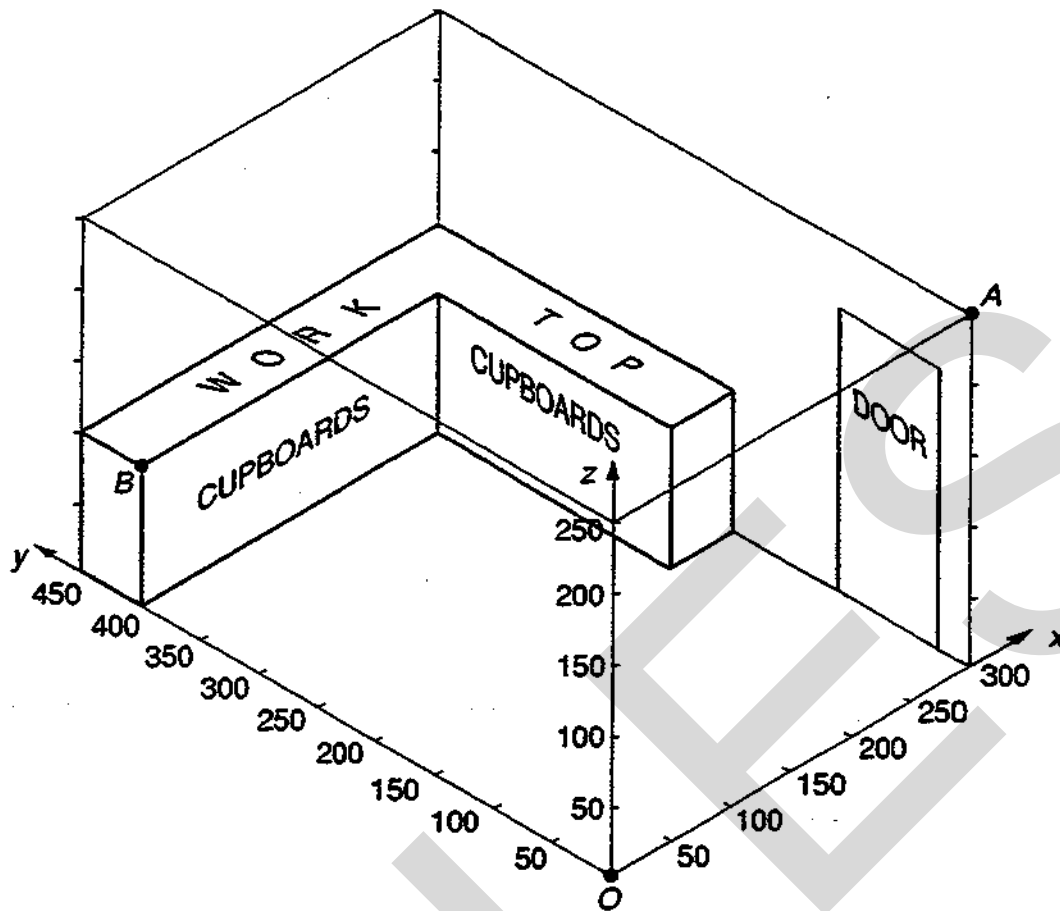

The diagram above is an isometric drawing of a kitchen with cupboards at floor level.

The kitchen is a cuboid 300 cm wide, 450 cm long and 250 cm high.

The work top above the cupboards is 100 cm above the floor and 50 cm wide.

(a) Another cupboard is to be fixed above the work top on the shorter wall.

It is a cuboid 300 cm long, 50 cm high and 25 cm from back to front.

Its top is to be 50 cm below the ceiling.

Draw this cupboard in the diagram.

[3]

(b) Axes  $Ox$ ,  $Oy$ ,  $Oz$  are taken as shown in the diagram.

Write down the coordinates of

(i) the point  $A$ ,

Answer (b) (i) \_\_\_\_\_

(ii) the point  $B$ .

Answer (b) (ii) \_\_\_\_\_

[3]



(c)

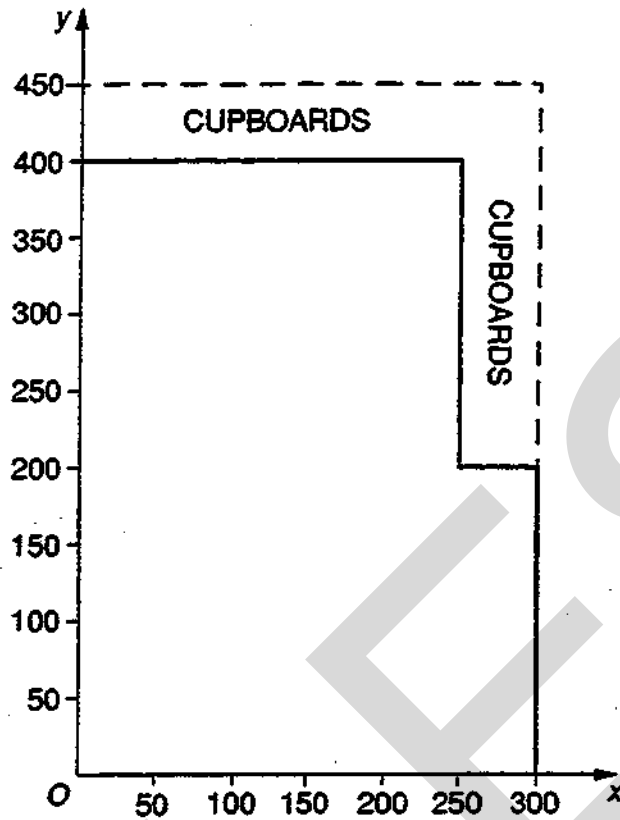

This is a scale drawing of the floor of the kitchen.

The part of the floor within 50 cm of the cupboards must be kept clear.

On the diagram, show clearly and accurately this part of the floor.

[3]

7 (a)

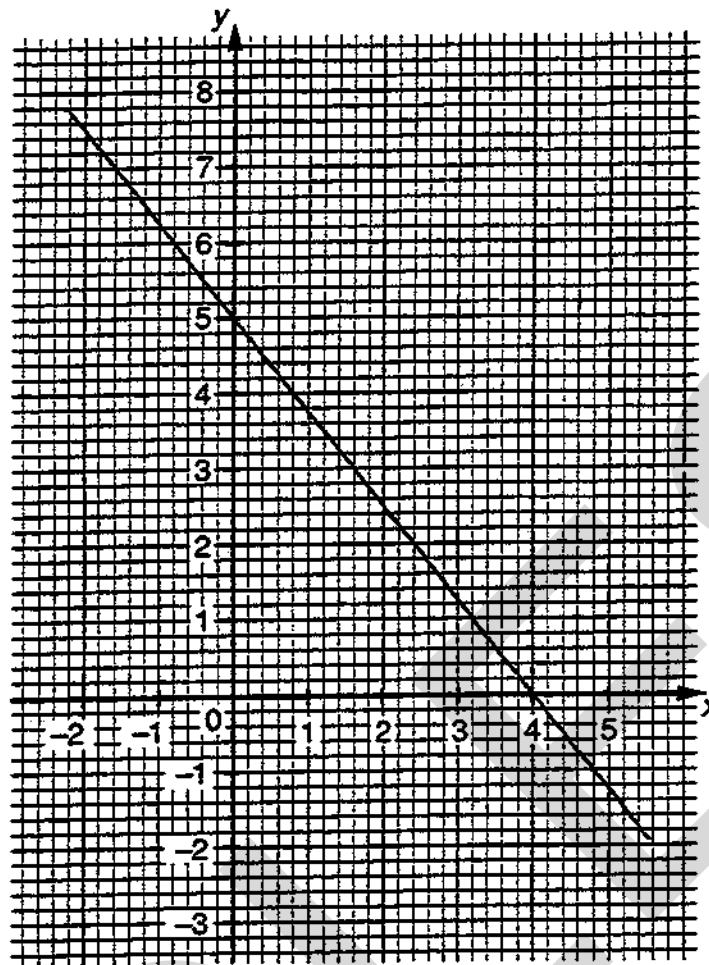

(i) The graph of  $5x + 4y = 20$  is shown on the diagram above.

On the diagram, draw the graph of  $y = 2x$ .

[3]

(ii) Use the graphs to find the solution of the simultaneous equations

$$5x + 4y = 20,$$

$$y = 2x.$$

Give the value of  $x$  and the value of  $y$  to one decimal place.

Answer (a) (ii)  $x = \underline{\hspace{2cm}}$ ,  $y = \underline{\hspace{2cm}}$  [2]

(b) Calculate the exact solution of the simultaneous equations

$$5x + 4y = 20,$$

$$2x - y = 0.$$

.....

.....

.....

.....

Answer (b)  $x = \underline{\hspace{2cm}}$ ,  $y = \underline{\hspace{2cm}}$  [4]

8

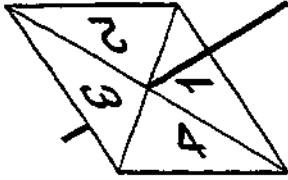

A spinner, with its edges numbered one to four, is biased.  
For one spin, the probability of scoring 1 is 0.2,  
the probability of scoring 3 is 0.3  
and the probability of scoring 4 is 0.15.

(a) Calculate the probability of scoring 2 with one spin.

.....

Answer (a) \_\_\_\_\_ [3]

(b) The spinner is used in a board game called 'Steeplechase'. In the game, a player's counter is moved forwards at each turn by the score shown on the spinner.

If the player's counter lands on one of the two squares numbered 27 and 28 (labelled 'WATER JUMP'), the player is out of the game.



(i) Ann's counter is on square 26.

Find the probability that she will not be out of the game after one more turn.

.....  
.....

Answer (b) (i) \_\_\_\_\_ [3]

(ii) Peter's counter is on square 25.

Find the probability that, after two more turns, his counter will be on square 29.

.....  
.....  
.....

Answer (b) (ii) \_\_\_\_\_ [3]

9

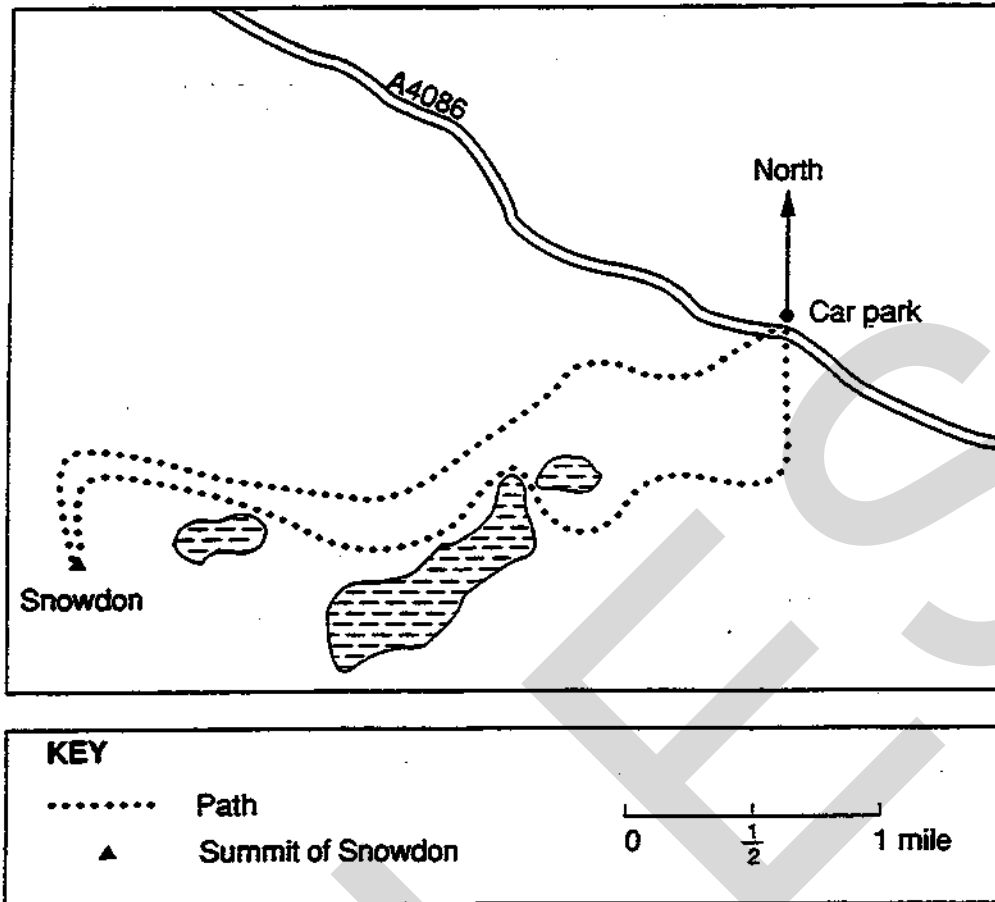

The map shows the path which Jan will use to walk from the car park on the A4086 road to the summit of Snowdon and back again.

- (a) From the car park, what is the three figure bearing of the summit of Snowdon?  
Show the angle clearly on the map.

Answer (a) \_\_\_\_\_ [3]

- (b) (i) The height of Snowdon above sea level is 3560 feet correct to the nearest whole number.

State the greatest and least possible values of this height.

Answer (b) (i) Greatest = \_\_\_\_\_ feet, Least = \_\_\_\_\_ feet [3]

(ii)

1 mile = 1609 m  
1 mile = 5280 feet

Use this information to express 3560 feet in metres.

.....  
 .....  
 .....  
 .....

Answer (b) (ii) \_\_\_\_\_ metres [3]

- (c) Estimate the distance, in miles, that Jan will walk. Show how you obtained your estimate.

.....  
 .....  
 .....

Answer (c) \_\_\_\_\_ miles [3]

- (d) The time the walk will take can be estimated by using the formula

$$T = \frac{D}{2} + \frac{V}{1200}$$

where  $T$  hours is the time taken,  
 $D$  miles is the distance walked  
 and  $V$  feet is the vertical height climbed.

The car park is 1171 feet above sea level.

Use the formula to estimate the time the walk will take.

.....  
 .....  
 .....

Answer (d) \_\_\_\_\_ [2]

10

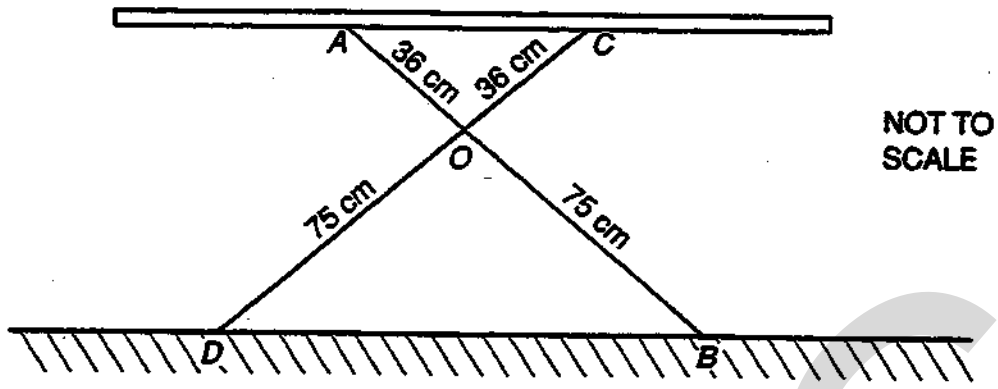

The diagram shows how an ironing board is supported by two legs  $AOB$  and  $COD$ . The legs are hinged at  $O$ , and  $C$  is hinged to the ironing board.

The distance between  $A$  and  $C$  can be varied.

- (a) (i) When angle  $BOD = 80^\circ$ , work out the size of angle  $OBD$ .

.....

Answer (a) (i) \_\_\_\_\_

- (ii) What facts about angles did you use?

Answer (a) (ii) \_\_\_\_\_

\_\_\_\_\_ [3]

(b) The ironing board is placed on a horizontal floor and adjusted so that  $BD = 92$  cm.

(i) Use Pythagoras' theorem to calculate the height of  $O$  above the floor.

.....

.....

.....

Answer (b) (i) \_\_\_\_\_ cm [3]

(ii) Use similar triangles to calculate the distance  $AC$ .

.....

.....

.....

Answer (b) (ii) \_\_\_\_\_ cm [3]

(iii) Calculate the size of angle  $OBD$ .

.....

.....

.....

Answer (b) (iii) \_\_\_\_\_ [3]

(c) The ironing board is adjusted again so that  $AC$  is 90 cm above the floor.

Calculate the height of  $O$  above the floor.

.....

.....

.....

Answer (c) \_\_\_\_\_ cm [3]

- 11 Vicki investigated the times taken to serve 120 customers at a supermarket called Pricewell. Her results are shown below.

Time (seconds)	20–30	30–40	40–50	50–60	60–70
Number of customers	4	17	48	16	35

- (a) (i) Calculate an estimate of the mean time to serve the customers.

.....

.....

.....

.....

.....

.....

Answer (a) (i) \_\_\_\_\_ seconds [3]

- (ii) Write down the modal class for the serving times.

Answer (a) (ii) \_\_\_\_\_ seconds [1]

Vicki decided to extend her investigation to another supermarket called Costsave. She obtained the times taken to serve 120 customers at Costsave. Her extended table is shown below.

Time (seconds)	20–30	30–40	40–50	50–60	60–70
Number of customers at Pricewell	4	17	48	16	35
Number of customers at Costsave	5	20	54	36	5



- (b) Vicki correctly worked out the mean and modal class for the times at Costsave. She also worked out correctly the median of the times for each supermarket.

Use your answers to part (a) to complete the table below.

	<i>Pricewell</i>	<i>Costsave</i>
median	48.1	46.5
modal class		40–50
mean		46.3

Which average in this table represents the data most fairly? Give a reason for your answer.

Answer (b) \_\_\_\_\_

\_\_\_\_\_

\_\_\_\_\_ [2]

**QUESTION 11 CONTINUES ON THE NEXT PAGE**

(c)

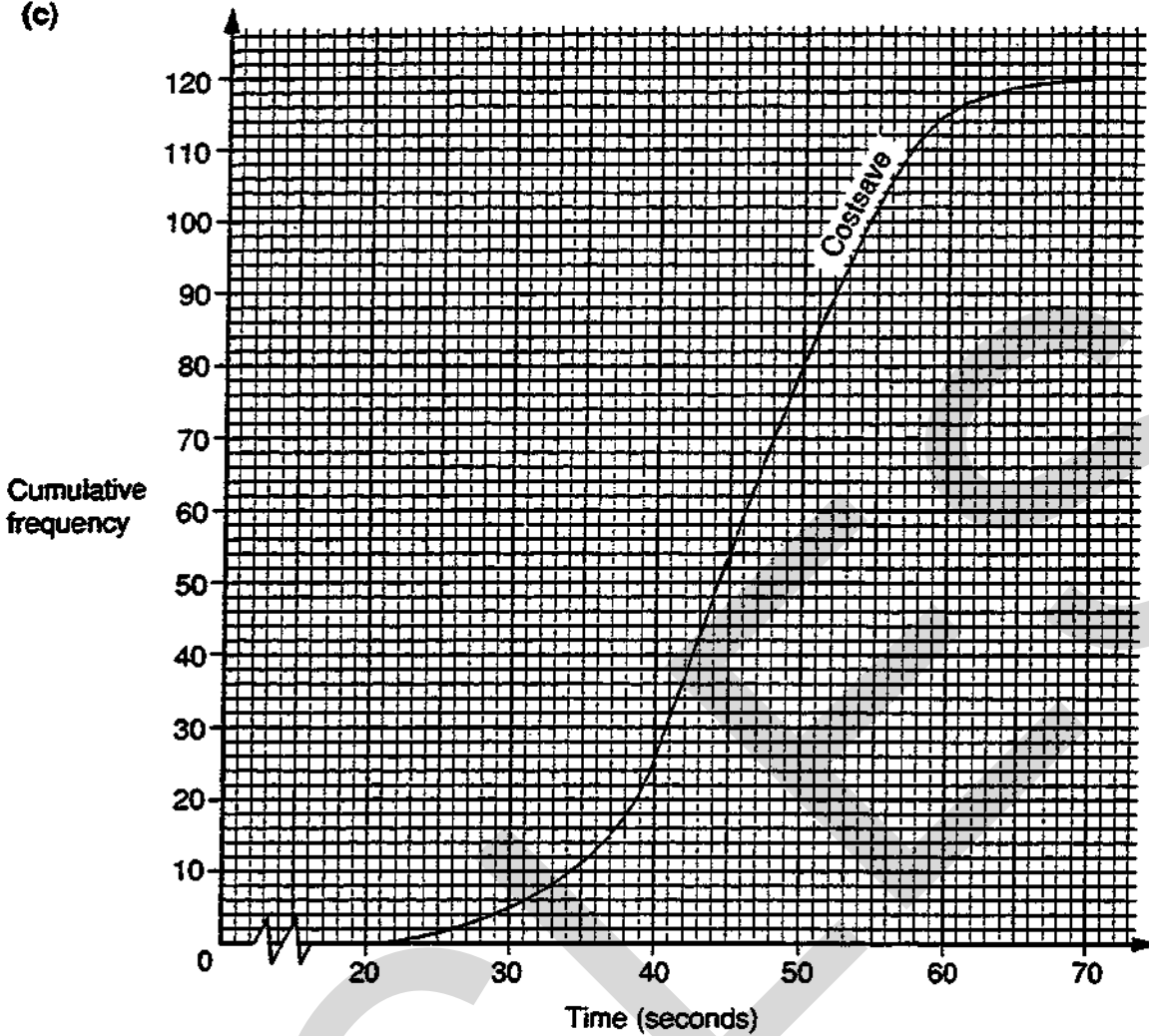

The graph shows the cumulative frequency curve for the serving times at Costsave.

(i) On the same axes, show the cumulative frequency curve for the serving times at Pricewell. For reference the table from page 18 is shown again below.

Time (seconds)	20-30	30-40	40-50	50-60	60-70
Number of customers at Pricewell	4	17	48	16	35
Number of customers at Costsave	5	20	54	36	5

.....

.....

.....

[2]

(ii) Complete the table below.

	<i>Pricewell</i>	<i>Costsave</i>
lower quartile		41
upper quartile		53
inter-quartile range		12

[2]

(iii) Use the information in the table to comment on the difference in the distributions of the serving times at Pricewell and Costsave.

Answer (c) (iii) \_\_\_\_\_

\_\_\_\_\_

\_\_\_\_\_ [2]

12

	Population (1990)	Area ( $\text{km}^2$ )	Area (acres)
England	$4.7689 \times 10^7$	$1.3048 \times 10^5$	$3.2242 \times 10^7$
Wales	$2.881 \times 10^6$	$2.077 \times 10^4$	$5.132 \times 10^6$

- (a) Calculate the average population per square kilometre for England.

.....  
 .....  
 .....

Answer (a) \_\_\_\_\_ [2]

- (b) Find the total area of England and Wales in acres.

.....  
 .....  
 .....

Answer (b) \_\_\_\_\_ acres [2]

- (c) Use information from the table to express 1 acre in square kilometres.  
 Show your working clearly and give your answer in standard form.

.....  
 .....  
 .....

Answer (c) \_\_\_\_\_  $\text{km}^2$  [3]

- 13 David is thinking of buying 120 hot dogs for £20 to sell at a charity fair.  
 He reckons that, if he priced them at 10p each, all of them would be sold.  
 The number sold would decrease steadily as the price increased.  
 At 90p each, none of the hot dogs would be sold.

The sketch graph below shows how the number of hot dogs sold ( $y$ ) depends on the price charged ( $x$  pence).

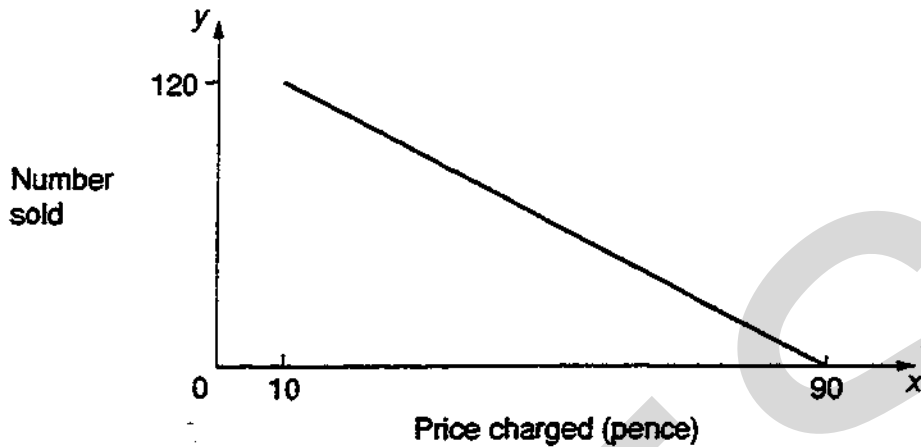

- (a) (i) If David is to sell at least 75 hot dogs, what is the greatest amount he could charge for each hot dog?

.....  
 .....  
 .....

Answer (a) (i) \_\_\_\_\_ pence [3]

- (ii) Taking into account that David would pay £20 for the hot dogs, how much profit would he make altogether if he charged 30p for each hot dog?

.....  
 .....  
 .....

Answer (a) (ii) £ \_\_\_\_\_ [3]

- (b) The relationship between  $x$  and  $y$  is

$$y = 135 - \frac{3}{2}x.$$

Obtain an expression, in terms of  $x$ , for the profit in £ David would make altogether if he charged  $x$  pence for each hot dog.

.....  
 .....  
 .....

Answer (b) \_\_\_\_\_ [3]

## SECTION B

Answer all questions in this section.

Write all your answers on the writing paper and graph paper provided.

Show all your working.

14 You may use graph paper for this question.

This question is about polygons whose interior angles are each  $90^\circ$  or  $270^\circ$ . They will be called 'right polygons'.

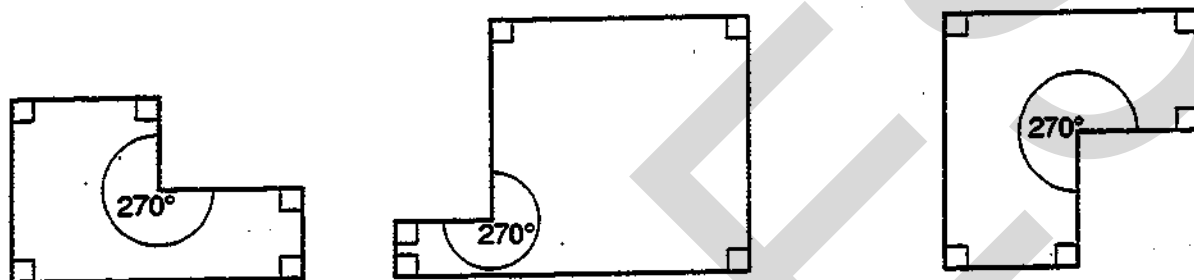

Each of these is a right polygon with 6 sides (a right hexagon). All right hexagons have exactly one angle of  $270^\circ$ .

- (a) (i) Draw a right polygon with 8 sides (a right octagon).  
 (ii) How many angles of  $270^\circ$  does your octagon have? [2]
- (b) (i) What is the sum of the six interior angles of a hexagon?  
 (ii) What is the sum of the eight interior angles of an octagon? [2]
- (c) (i) Explain why it is not possible to draw a right polygon with  $n$  sides where  $n = 3$ .  
 (ii) Write down another whole number  $n$  for which it is not possible to draw a right polygon with  $n$  sides. [4]
- (d) Investigate how the number of interior angles of  $270^\circ$  in a right polygon depends on the number of sides in the polygon. Present your results clearly. [7]

15 You must use graph paper for part (a) (ii) of this question.

Look at this sequence:

2, 6, 4, 5, 4.5, 4.75, .....

After the first two terms (the 'starting terms'), each term is the mean of the two previous terms.

In this example

$$\frac{2+6}{2} = 4, \quad \frac{6+4}{2} = 5, \quad \frac{4+5}{2} = 4.5, \quad \frac{5+4.5}{2} = 4.75.$$

This type of sequence will be called a 'mean sequence'.

(a) (i) Copy and complete the following table.

Position of term in the sequence ( $x$ )	1st	2nd	3rd	4th	5th	6th	7th	8th	9th
Term ( $y$ )	2	6	4	5	4.5	4.75			

[2]

(ii) Draw a graph to show how the terms vary.

[2]

(iii) Now consider other mean sequences with starting terms different from those used in the example above.

Investigate whether the terms vary in a similar way.

[7]

(b) 'If  $a$ ,  $b$ ,  $c$  are three consecutive terms in a mean sequence, then  $a \leq bc$ .'

Show that this statement is not always true.

[4]

Centre Number	Candidate Number

Candidate Name \_\_\_\_\_

**MIDLAND EXAMINING GROUP**  
**General Certificate of Secondary Education**  
**MATHEMATICS (without Course Work)**  
**PAPER 6 (Further Tier)**

**1660/6**

Friday                      **10 JUNE 1994**                      Morning                      2 hours 30 minutes

Additional materials:  
 Answer paper  
 Electronic calculator  
 Geometrical instruments  
 Graph paper (1 sheet)  
 Tracing paper (optional)

**TIME** 2 hours 30 minutes

**INSTRUCTIONS TO CANDIDATES**

Write your name, Centre number and candidate number in the spaces at the top of this page and on all separate answer paper used.

Show all your working. Marks may be given for working which shows that you know how to solve the problem, even if you get the answer wrong.

**Section A**

Answer **all** questions.

Write your answers in the spaces provided on the question paper.

**Section B**

Answer **all** questions.

Write your answers on the writing and graph paper provided.

At the end of the examination, fasten the separate answer paper securely to the question paper, with the question paper **on top of** the answer paper.

**INFORMATION FOR CANDIDATES**

The number of marks is given in brackets [ ] at the end of each question or part question.

You are expected to use an electronic calculator for this paper.

Unless otherwise instructed in the question, take  $\pi$  to be 3.142 or use the  $\pi$  button on your calculator.

FOR EXAMINER'S USE

**This question paper consists of 20 printed pages.**



# INFORMATION AND FORMULAE

## MENSURATION

### Parallelogram

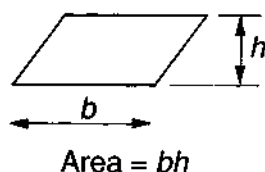

### Trapezium

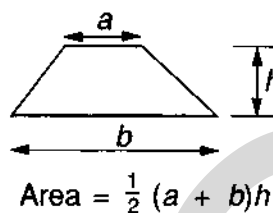

Cylinder (radius  $r$ , height  $h$ )

Area of curved surface =  $2\pi rh$

Sphere (radius  $r$ )

Volume =  $\frac{4}{3}\pi r^3$   
Area of surface =  $4\pi r^2$

Prism (including cylinder)

Volume = area of cross-section  $\times$  length

Pyramid (including cone)

Volume =  $\frac{1}{3} \times$  area of base  $\times$  height

Cone (radius  $r$ , height  $h$ )

Area of curved surface =  $\pi r\ell$   
where  $\ell$  = slant height =  $\sqrt{h^2 + r^2}$

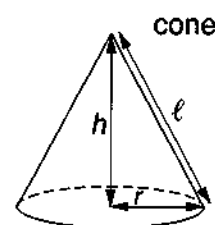

## TRIGONOMETRY

### Right-angled triangle

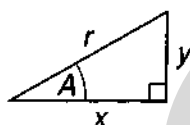

$r^2 = x^2 + y^2$ , (result of Pythagoras)

$x = r \cos A$ ,  $y = r \sin A$ ,  $y = x \tan A$

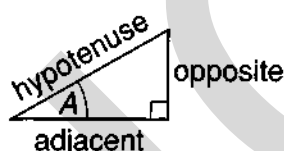

$\sin A = \frac{\text{opposite}}{\text{hypotenuse}}$ ,  $\cos A = \frac{\text{adjacent}}{\text{hypotenuse}}$ ,  $\tan A = \frac{\text{opposite}}{\text{adjacent}}$

### Any triangle

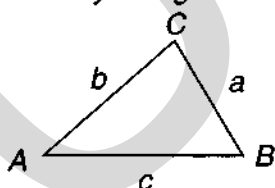

In any triangle  $ABC$ :  $\frac{a}{\sin A} = \frac{b}{\sin B} = \frac{c}{\sin C}$

$a^2 = b^2 + c^2 - 2bc \cos A$

$\cos A = \frac{b^2 + c^2 - a^2}{2bc}$

Area of triangle  $ABC = \frac{1}{2} ab \sin C$

**NUMBER** Standard form is  $a \times 10^n$  where  $1 \leq a < 10$  and  $n$  is an integer.

Compound Interest formula  $A = P \left(1 + \frac{r}{100}\right)^n$

**ALGEBRA** The quadratic equation  $ax^2 + bx + c = 0$  has solutions

$$x = \frac{-b \pm \sqrt{b^2 - 4ac}}{2a}$$

## SECTION A

Answer all questions in this section.

Write your answers in the spaces provided on the question paper.

Show all your working.

- 1 (a) In a practical test a teacher asks one of her students to measure a distance the teacher knows to be exactly 12 metres. She offers the student a ruler 15 cm long or a tape 3 m long.

Which is the more accurate for the student to use? Give a reason for your answer.

Answer (a) \_\_\_\_\_

\_\_\_\_\_ [2]

- (b) From a metal rod 50 cm long, a piece 15 cm long is cut off. Each of these measurements is correct to the nearest centimetre.

- (i) What was the greatest possible length of the metal rod?

Answer (b) (i) \_\_\_\_\_ cm

- (ii) What is the smallest possible length of the piece cut off?

Answer (b) (ii) \_\_\_\_\_ cm

- (iii) Find the difference between the answers to parts (i) and (ii). What information does this give about the length of rod remaining?

Answer (b) (iii) \_\_\_\_\_

\_\_\_\_\_ [4]

- 2 The following list shows the maximum daily temperature, in °F, throughout the month of April.

56.1	49.4	63.7	56.7	55.3	53.5	52.4	57.6	59.8	52.1
45.8	55.1	42.6	61.0	61.9	60.2	57.1	48.9	63.2	68.4
55.5	65.2	47.3	59.1	53.6	52.3	46.9	51.3	56.7	64.3

- (a) Complete the grouped frequency table below.

Temperature, $T$		Frequency
$40 < T \leq 50$		
$50 < T \leq 54$		
$54 < T \leq 58$		
$58 < T \leq 62$		
$62 < T \leq 70$		

[2]

- (b) Use your table of values in part (a) to calculate an estimate of the mean of this distribution. You **must** show your working clearly.

.....

.....

.....

.....

Answer (b) \_\_\_\_\_ [4]

(c) On the grid below draw a histogram to represent your distribution in part (a).

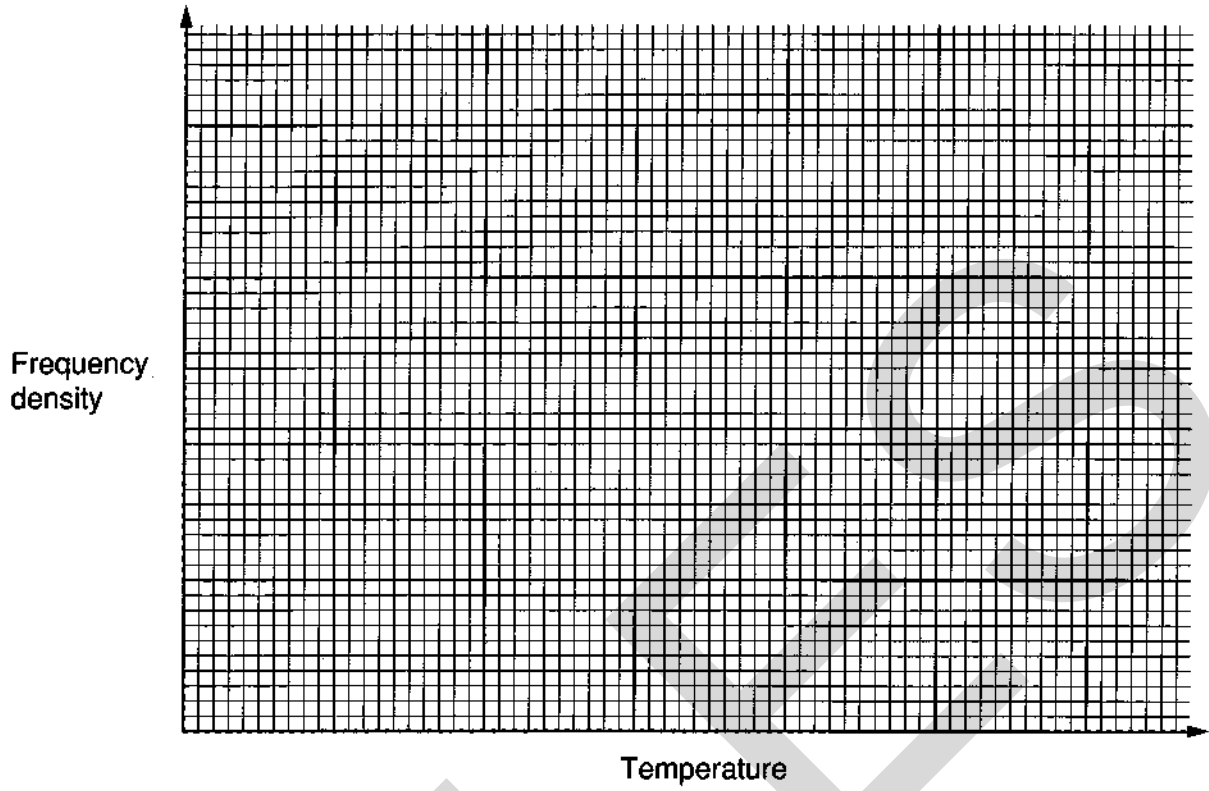

[4]

- 3 The height,  $h$  metres, of a sky rocket  $t$  seconds after being launched is given by the formula

$$h = at^2 + bt + 2$$

where  $a$  and  $b$  are constants. The heights of the rocket above the ground at two different times are given in the table below.

$t$ (seconds)	1	2
$h$ (metres)	37	62

- (a) At what height above the ground is the rocket launched?

.....  
 Answer (a) \_\_\_\_\_ m [2]

- (b) (i) Use the table of values to show that

$$a + b = 35$$

$$\text{and } 4a + 2b = 60.$$

Answer (b) (i) \_\_\_\_\_  
 \_\_\_\_\_  
 \_\_\_\_\_  
 \_\_\_\_\_ [2]

- (ii) Solve these simultaneous equations to find the value of  $a$  and the value of  $b$ .

.....  
 .....  
 .....  
 .....

Answer (b) (ii)  $a =$  \_\_\_\_\_  
 $b =$  \_\_\_\_\_ [4]

- (c) What was the height of the sky rocket  $7\frac{1}{2}$  seconds after it was launched?

.....  
 .....  
 .....

Answer (c) \_\_\_\_\_ m [2]

4

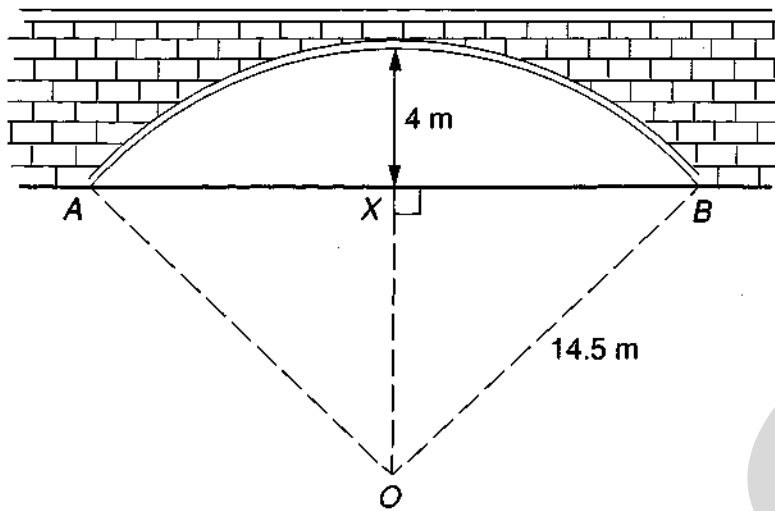

NOT TO  
SCALE

The diagram shows the cross-section of a tunnel which has a maximum height of 4 m above its horizontal base  $AB$ . The roof of the tunnel is part of a circle, centre  $O$  and radius 14.5 m. The mid point of  $AB$  is  $X$ .

(a) (i) Write down the length of  $OX$ .

Answer (a) (i) \_\_\_\_\_ m

(ii) Calculate the length of  $AB$ .

.....

.....

.....

Answer (a) (ii) \_\_\_\_\_ m

[4]

(b) Calculate the size of angle  $BOX$ .

.....

.....

.....

Answer (b) \_\_\_\_\_ [3]

(c) Calculate the area of cross-section of the tunnel.

.....

.....

.....

Answer (c) \_\_\_\_\_  $m^2$  [4]

- 5 The number of coins,  $N$ , with diameter  $d$  cm and with a fixed thickness that can be made from a given volume of metal can be found by using the formula

$$N = \frac{k}{d^2}$$

where  $k$  is a constant.

- (a) Given that 5000 coins of diameter 2.5 cm can be made from the volume of metal, find the value of  $k$ .

.....  
.....  
.....

Answer (a) \_\_\_\_\_ [2]

- (b) Calculate how many coins of diameter 2 cm can be made from an equal volume of metal.

.....  
.....  
.....

Answer (b) \_\_\_\_\_ [2]

- (c) Rearrange the formula  $N = \frac{k}{d^2}$  to make  $d$  the subject.

.....  
.....  
.....

Answer (c) \_\_\_\_\_ [2]

- (d) 2000 coins are to be made using an equal volume of metal. Calculate the diameter of these coins.

.....  
.....  
.....

Answer (d) \_\_\_\_\_ [2]

- 6 The diagram represents a stepladder made of two sections  $AB$  and  $BC$ .

A bar  $PQ$ , parallel to  $AC$ , is used to stabilise the ladder.

$AB = 2.5$  metres,  $PQ = 1.2$  metres and  $AC = 1.7$  metres.

Calculate the length of  $BP$ .

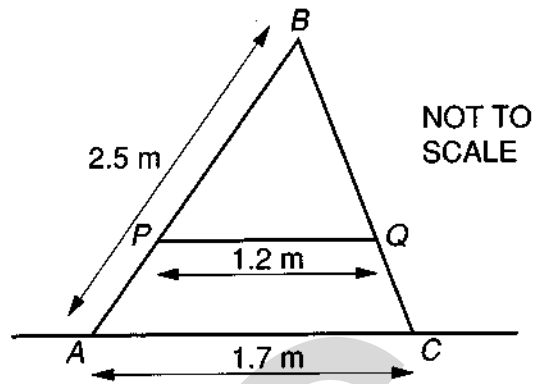

.....

.....

.....

Answer \_\_\_\_\_ m [3]

- 7 (a) A Mathematics student attempted to define an “irrational number” as follows:

“An irrational number is a number which, in its decimal form, goes on and on.”

- (i) Give an example to show that this definition is not correct.

Answer (a) (i) \_\_\_\_\_

\_\_\_\_\_

\_\_\_\_\_ [3]

- (ii) What must be added to the definition to make it correct?

Answer (a) (ii) \_\_\_\_\_ [2]

- (b) Which of the following numbers are rational and which irrational?

$$\sqrt{4\frac{1}{4}}, \quad \sqrt{6\frac{1}{4}}, \quad \frac{1}{3} + \sqrt{3}, \quad \left(\frac{1}{3}\sqrt{3}\right)^2$$

Express each of the rational numbers in the form  $\frac{p}{q}$  where  $p$  and  $q$  are integers.

Answer (b) \_\_\_\_\_

\_\_\_\_\_

\_\_\_\_\_

\_\_\_\_\_ [3]



- 8 (a) 50 pupils take an English exam and a Maths exam. The distribution of the marks they obtained is shown in the table below.

Mark		21-30	31-40	41-50	51-60	61-70	71-80	81-90	91-100
Number of pupils	English exam	0	1	4	20	14	8	2	1
	Maths exam	2	3	6	10	12	10	4	3

The graph below shows the cumulative frequency for the English marks.

- (i) On the graph, show the cumulative frequency for the Maths marks. [2]

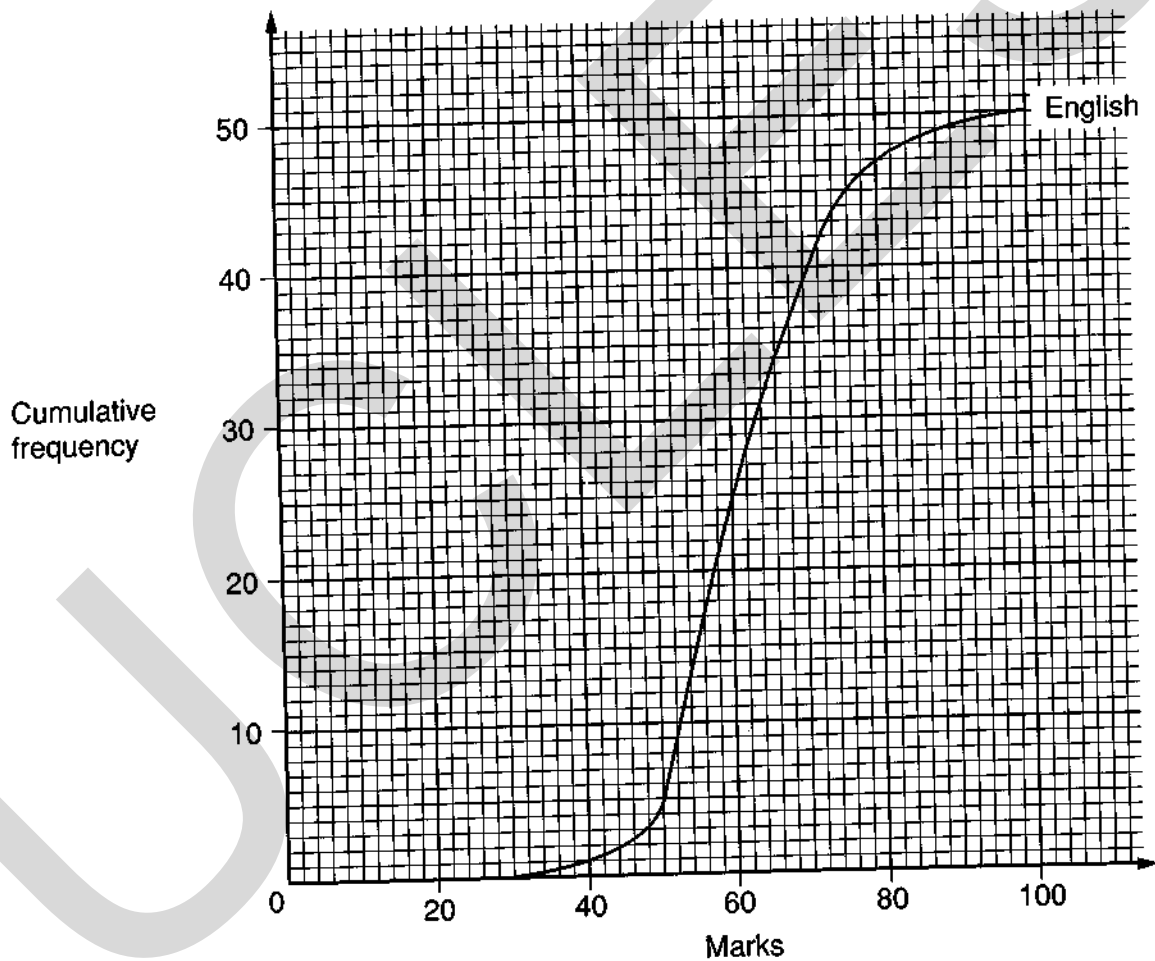

(ii) Complete the table below.

	English	Maths
Median	60	
Inter-quartile Range	14	

[2]

.....

.....

(iii) Use the information in the table to comment on the differences between the two distributions of marks.

Answer (a) (iii) \_\_\_\_\_

\_\_\_\_\_

\_\_\_\_\_

[2]

(b) Of the 50 pupils, 30 pass the Maths exam at the first attempt. From past performance it is known that, if a pupil fails at the first attempt, the probability of passing at the second attempt is 0.7. Calculate the probability that a pupil, chosen at random from the 50 pupils, will pass the Maths exam at either the first or second attempt.

.....

.....

.....

.....

.....

.....

.....

.....

Answer (b) \_\_\_\_\_ [5]

- 9 John places a cake in his freezer. The temperature,  $T$  °C, of the cake after  $t$  minutes is given by the formula

$$T = 32(2^{-t}) - 18.$$

- (a) Complete the table below.

$t$ (minutes)	0	1	2	3	4
$T$ (°C)					

[3]

- (b) Draw the graph of  $T$  against  $t$ .

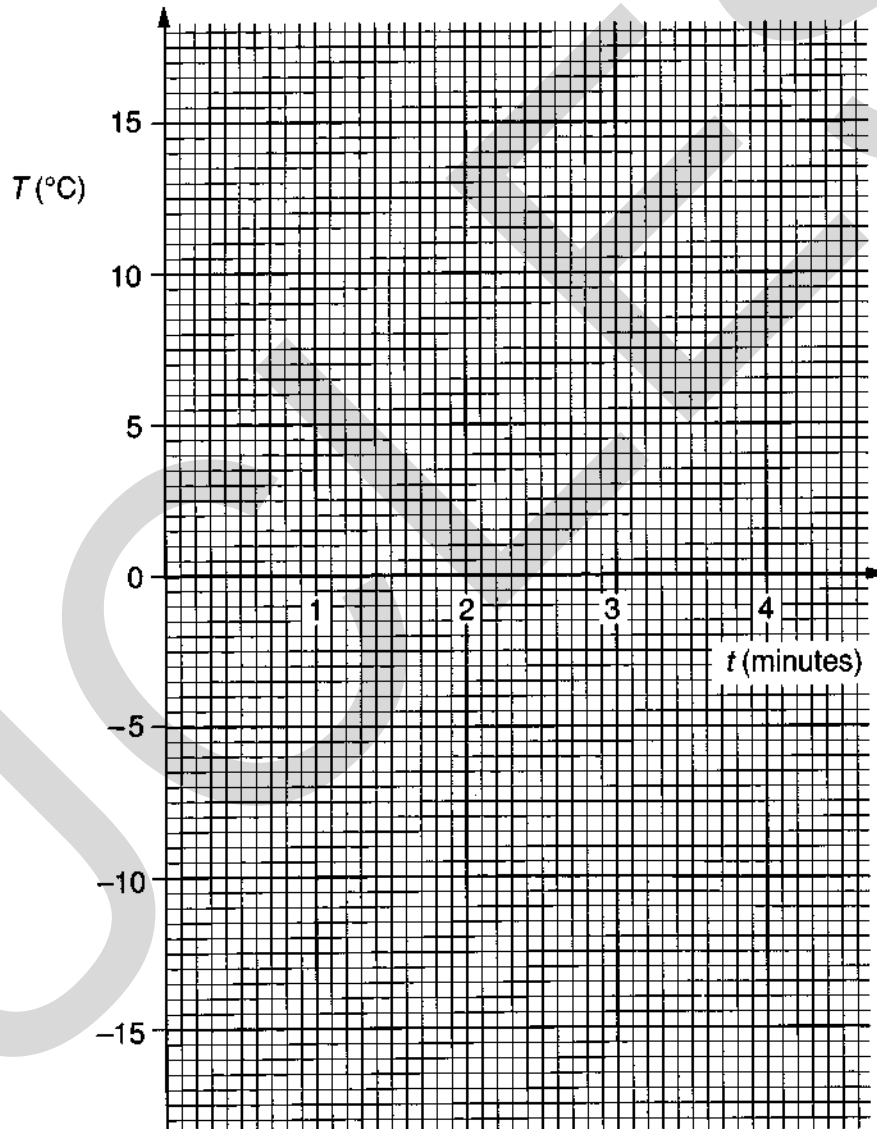

[2]

- (c) John knows that the cake's temperature is  $14^{\circ}\text{C}$  when he places it in the freezer. He does not know the formula for its temperature after  $t$  minutes.

He estimates that its temperature will fall by  $10^{\circ}\text{C}$  every minute.

On the grid, draw the graph showing how John thinks the temperature will vary during the first three minutes. [3]

- (d) Use your graph to find the time when the estimated temperature is the same as the true temperature of the cake.

Answer (d) \_\_\_\_\_ minutes [1]

---

**10** Two wine bottles have similar shapes.  
 The standard bottle has a height of 30 cm and  
 the small bottle has a height of 23.5 cm.

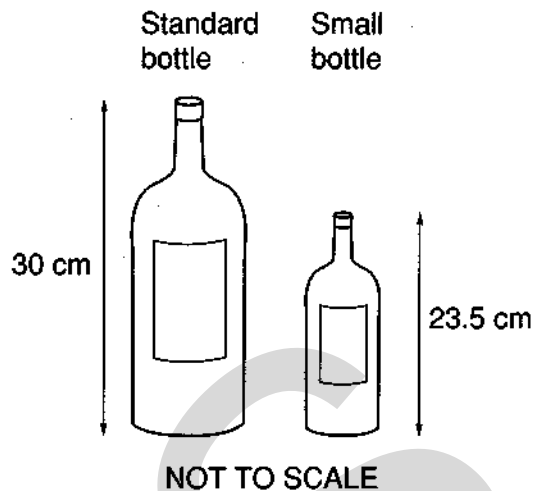

**(a)** Calculate the ratio of the areas of the bases of the two bottles.

Give your answer in the form  $n : 1$ .

.....

.....

.....

Answer (a) \_\_\_\_\_ [3]

**(b)** What is the ratio of the volumes of the two bottles?

Give your answer in the form  $n : 1$ .

.....

.....

.....

Answer (b) \_\_\_\_\_ [2]

**(c)** Is it a fair description to call the small bottle a 'half bottle'? Give a reason for your answer.

Answer (c) \_\_\_\_\_

\_\_\_\_\_ [1]

11 In the diagram below, the line  $AB$  is 8 cm long.

- (a) Draw the locus of points,  $P$ , which lie above the line  $AB$  such that the area of triangle  $ABP$  is  $12 \text{ cm}^2$ . [2]
- (b) On the same diagram construct the locus of points,  $Q$ , which lie above the line  $AB$  such that angle  $AQB$  is  $90^\circ$ . [3]
- (c) Hence draw all triangles  $ABC$  which have  $C$  above  $AB$ , an area of  $12 \text{ cm}^2$  and an angle of  $90^\circ$ . [2]

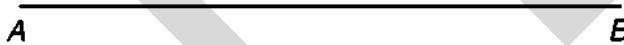

12

NOT TO  
SCALE

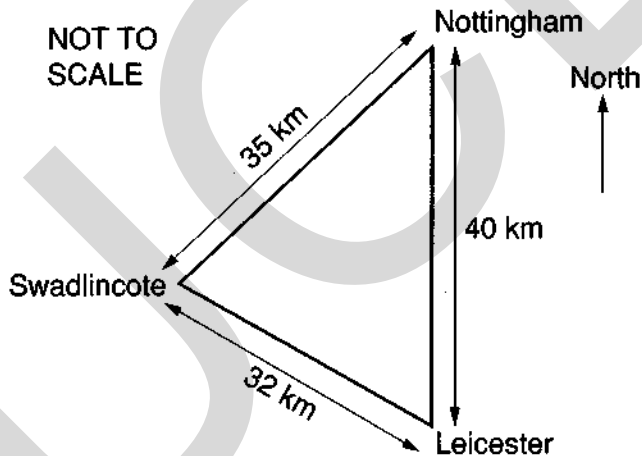

Nottingham is 40 km due North of Leicester. Swadlincote is 32 km from Leicester and 35 km from Nottingham.

Calculate the bearing of Swadlincote from Leicester.

.....

.....

.....

.....

Answer \_\_\_\_\_ [4]

13 In this question, take  $\pi$  to be 3.142 or use the  $\pi$  button on your calculator.

A cylindrical tin of soup has a base radius of 3.7 cm and height of 11.1 cm, both measurements correct to one decimal place.

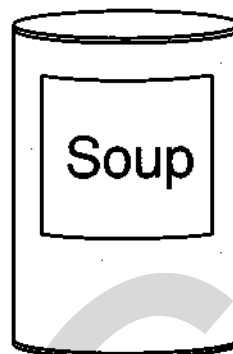

NOT TO  
SCALE

- (a) Given that 5000 such tins must be filled, calculate the volume of soup necessary to be certain of filling all the tins.

.....

.....

.....

.....

Answer (a) \_\_\_\_\_ cm<sup>3</sup> [2]

- (b) Calculate the maximum number of tins that could be filled with this volume of soup.

.....

.....

.....

.....

Answer (b) \_\_\_\_\_ [2]

14 (a) (i) Show that

$$x = 1 + \frac{11}{x-3}$$

is a rearrangement of the equation  $x^2 - 4x - 8 = 0$ .

Answer (a) (i) \_\_\_\_\_

.....

.....

.....

.....

[3]

- (ii) Use the iterative formula

$$x_{n+1} = 1 + \frac{11}{x_n - 3}$$

together with a starting value of  $x_1 = -2$  to obtain a root of the equation  $x^2 - 4x - 8 = 0$  accurate to 1 decimal place.

.....

.....

.....

.....

.....

Answer (a) (ii) \_\_\_\_\_ [2]

- (b) (i) Use the quadratic equation formula to solve the equation

$$x^2 - 4x - 8 = 0.$$

.....

.....

.....

.....

Answer (b) (i) \_\_\_\_\_ [3]

- (ii) Comment on how the answer to part (b) (i) compares with your answer to part (a) (ii).

Answer (b) (ii) \_\_\_\_\_

\_\_\_\_\_ [1]



15

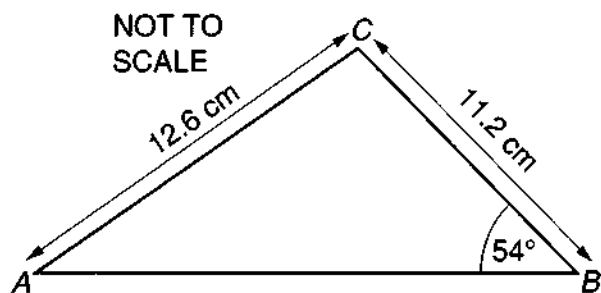

In triangle  $ABC$ ,  $AC = 12.6$  cm,  $BC = 11.2$  cm and angle  $B = 54^\circ$ . The lengths  $AC$  and  $BC$  are correct to the nearest millimetre and angle  $B$  is correct to the nearest degree.

Use the Sine Rule

$$\frac{\sin A}{a} = \frac{\sin B}{b}$$

to calculate the smallest possible value of angle  $A$ .

.....

.....

.....

.....

.....

.....

.....

Answer \_\_\_\_\_ [5]

- 16 In a survey on examination qualifications, 50 people were asked 'How many subjects are listed on your GCSE certificate?' The frequency distribution of their responses is recorded in the table below.

<i>Number of subjects</i>	<i>Number of people (frequency)</i>
1	5
2	3
3	7
4	8
5	9
6	10
7	8

- (a) Calculate the mean and standard deviation of the distribution.

.....

.....

.....

.....

.....

Answer (a) Mean = \_\_\_\_\_

Standard deviation = \_\_\_\_\_

[6]

- (b) 'A Normal Distribution has approximately 68% of its data values within one standard deviation of the mean.'

Use your answers to part (a) to check if the given distribution satisfies this property of a Normal Distribution. Show your working clearly.

Answer (b) \_\_\_\_\_

\_\_\_\_\_

\_\_\_\_\_

[3]

## SECTION B

Answer all questions in this section.

Write all your answers on the writing and graph paper provided.

Show all your working.

17 You must use graph paper for part (a) (ii) of this question.

The school shot put record is 15 metres.

Looking in an 'A' level text book, Stefan finds a diagram and a formula connecting the speed,  $V$  metres per second, and the angle,  $x^\circ$ , of the throw and the range achieved,  $R$  metres.

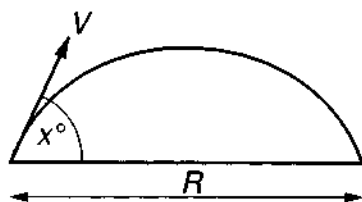

$$R = \frac{V^2}{5} \times (\sin x^\circ) \times (\cos x^\circ)$$

(a) Stefan knows that he can throw the shot with a speed of 12 m/s.

- (i) Use this information and the given formula to find the range he can achieve for different values of the angle  $x^\circ$ .
- (ii) Draw a graph to display this information.
- (iii) Comment on your findings.

[10]

(b) After some training Stefan finds that he can throw at a maximum speed of 13.2 m/s. Investigate different ways he can now beat the record. [5]

18 (a) (i) Verify that the formula for the  $n$ th triangle number is

$$\frac{n(n+1)}{2}$$

(ii) Prove that 171 is a triangle number.

[8]

(b) 'The sum of two consecutive triangle numbers is equal to a square number.'

- (i) Investigate this statement.
- (ii) Prove that the statement is true.

[7]